

ICCOC

Integrated CAD/CAM
Operations into CNC-
based machines

- [Home Page](#)
- [Industrial benefits](#)
- [Success Story](#)
- [Press Release](#)

The ICCOC Project

- [Objectives](#)
- [Executive Summary](#)
- [State of the Art](#)
- [The Approach](#)
- [Results](#)
- [Conclusions](#)
- [Partners](#)
- [Contact Person](#)
- [The TTN](#)

An activity with
[TETRApc TTN](#),
ESPRIT IV HPCN

 visitors

ICCOC

All in a click



"Using **ICCOC**, CNC user can access directly Unix CAD/CAM application from Windows NT CNC console, thus **saving 60% of time** for Re-CAD and Re-CAM operations. We have **improved the productivity of 20%**"

Massimo Giorgetti - TECMA S.r.l.

"Con **ICCOC**, gli operatori delle macchine a controllo numerico possono utilizzare direttamente sulla console Windows NT del CNC le applicazioni CAD e CAM Unix, **diminuendo del 60% il tempo necessario** per le operazioni di Re-CAD e Re-CAM. Abbiamo **aumentato la produttività del 20%**"

Massimo Giorgetti - TECMA S.r.l.

- [Dead time reduction of about 60%](#)
- [How to improve productivity of about 20%](#)
- [Requalification of CNC operators](#)

- [Eliminare il 60% dei tempi morti](#)
- [Come aumentare la produttività della vostra azienda del 20%](#)
- [Riquilificare gli operatori CNC](#)

The other pages of this site are available in English only

Le altre pagine di questo sito sono disponibili solo in inglese

ICCOC URL: <http://aguirre.dsi.unifi.it/~hpcn/wwwiccoc/wwwpag.html>



ICCOC

All in a click



"Using **ICCOC**, CNC user can access directly Unix CAD/CAM application from Windows NT CNC console, thus saving 60% of time for Re-CAD and Re-CAM operations. We have improved the productivity of 20%"

Massimo Giorgetti - TECMA S.r.l.

"Con **ICCOC**, gli operatori delle macchine a controllo numerico possono utilizzare direttamente sulla console Windows NT del CNC le applicazioni CAD e CAM Unix, diminuendo del 60% il tempo necessario per le operazioni di Re-CAD e Re-CAM. Abbiamo aumentato la produttività del 20%"

Massimo Giorgetti - TECMA S.r.l.

- Dead time reduction of about 60%
- How to improve productivity of about 20%
- Requalification of CNC operators

- Eliminare il 60% dei tempi morti
- Come aumentare la produttività della vostra azienda del 20%
- Riqualificare gli operatori CNC

The other pages of this site are available in *English only*

Le altre pagine di questo sito sono disponibili *solo in inglese*

ICCOC URL: <http://aguirre.dsi.unifi.it/~hpcn/wwwiccoc/wwwpag.html>

60% Dead Time Reduction

60% Dead Time Reduction

Some examples taken from companies needs follows:

All the time that your employers uses going around to carry paper, electronics supports and ask modifications to other employers are dead times for your company !!!

With ICCOC you can use CAD and CAM directly on the Elexa CNC console and, therefore, all the necessary modification can be performed without moving from the work place.



UNIX CAD in an NT CNC Console. Click to see a more detailed image ([43 Kb](#))



UNIX CAM in an NT CNC Console. Click to see a more detailed image ([98 Kb](#))

Consider a running CNC that has no problems, the operator is constrained to stay in front of the CNC without performing any productive activity.

By now with ICCOC your employer can modify some CAM parameters or adapt the NEXT piece to be done for its CNC.

The client main window of ICCOC demonstrator: FACTO. All operation, like, CAD, CAM, File Transfer, etc. are available on a single mouse click. [Click here](#) to see the snapshots, showing the various ICCOC facilities.

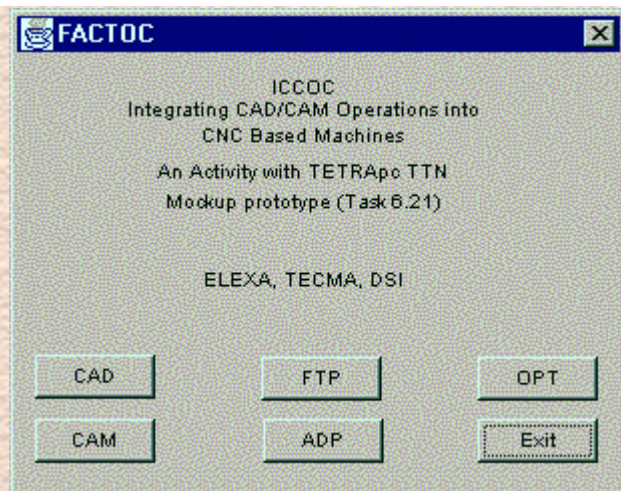

Yes the NEXT piece, because ICCOC optimizer says to the operator which is the next work to perform saving time to ask instructions from the department boss.

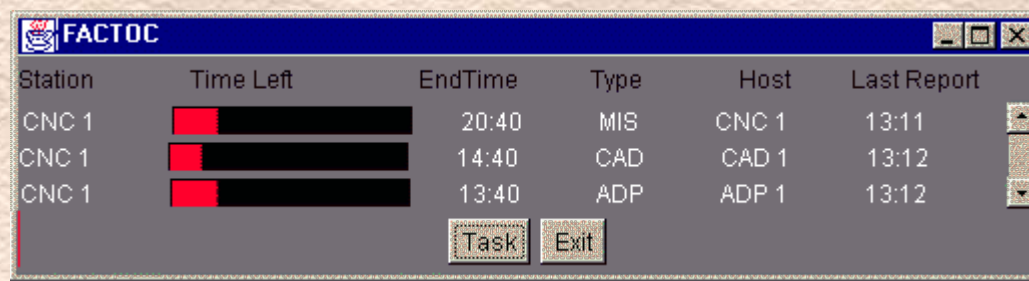

The FACTO Client Optimizer shows to the operator all the operation to be performed on the CNC that he controls.

20% improvement in productivity
20% improvement in productivity

Considering that you have a 60% reduction of dead time in Re-CAD, Re-CAM, going around and so on (activity that cover about 25% of your employers time) you can improve your productivity of 15%.

The remaining 5% of improvement is given to you by the facto optimizer that can help you to select free resources at the correct time, reschedule your works in any moment reducing further dead time and improving again and again productivity.



The FACTO Server shows to the manager all the work (and their status in real time) for all the CNCs and CAD/CAM/Adaption stations in the factory.

Requalify CNC Operators

Requalify CNC Operators

Using ICCOC your employers will acquire more knowledge about all the instruments used in your company. They will be able to solve some minor problems without the assistance of a CAD or a CAM operator that can continue to work on other projects reducing time to market for your company.

ICCOC URL: <http://aguirre.dsi.unifi.it/~hpcn/wwwiccoc/wwwpag.html>



FACTORY INTEGRATION: CAD/CAM ON MACHINE TOOLS

ELEXA & TECMA

ICCOC project has demonstrated the possibility of integration of CAD/CAM functionality on CNC-based machines by means of HPCN technology. The integration of CAD/CAM allows the reduction of costs related to non planned CAD/CAM activities of at least 35 %. Milling Machines, for making templates are typically used for producing unique and special templates. These usually need several CAD/CAM remakes on the basis of the machine adopted, on the machine configuration, and on the shape of the coarse piece from which the template is obtained. These facts and the lack of integration between CAD/CAM and MMs areas cause large problems of delay. The main result has been to pose the basis of implementing a new category of products for integrating CAD/CAM and MMs areas obtaining an optimal exploitation of resources. This has allowed the opening and the conquer of a new market, and as well as the consolidation of the present market. This activity was carried out under the TETRApc TTN. TETRApc can be contacted by email (nesi@dsi.unifi.it, nesi@ingfi1.ing.unifi.it) or by telephone (+39-055-4796523) or FAX (+39-055-4796363). The initial contact is Paolo Nesi.

[Click here to see or download full version of success story \(87 Kb\)](#)



ICCOC URL: <http://aguirre.dsi.unifi.it/~hpcn/wwwiccoc/wwwpag.html>



F.Butera, B.Fontanella, P.Nesi and M.Perfetti "*Reengineering a Computerized Numerical Control Towards Object-Oriented*", In Proc. of CSMR 98 pagg. 224-227, Florence Italy, March 8-11 1998

F.Butera, P.Nesi and M.Perfetti, "*CNC di Qualità per Produzioni di Qualità*", Meccanica & Macchine di Qualità, Rivista Italiana della Sicurezza e della Certificazione, Roma, n.1, pp.10-19, 1998.

Elexa and Tecma, "*Factory Integration: CAD/CAM on Machine Tools*", ICCOC Success Story ([see or download in PDF format 87K](#))

Elexa, DSI and Tecma, "*Public Final Report of ICCOC: Integrated CAD/CAM Operation into CNC-based machines*", ([see or download in PDF format 265K](#))

ICCOC URL: <http://aguirre.dsi.unifi.it/~hpcn/wwwiccoc/wwwpag.html>



The objective of this project has been the identification of a suitable network to support the integration between the CAD/CAM area and the machine area so to allow a reliable and fast remote execution of CAD/CAM applications on MMs console concurrently to the machine control, the dynamic optimization of CAD, CAM and MMs resources, fast and reliable transferring of very large quantity of data.

[ELEXA \(the technical consumer of this project\) point of view.](#)

The improvement of the integration between the CAD/CAM area and the Machine Tools should encompass the hereinafter aspects:

- remote execution of CAD, CAM directly on the CNCs of the Milling Machines
- transferring of files among the several workstations of the factory should be implemented by using FTP or other higher level more reliable mechanisms
- monitoring the activity of the factory
- advertising (remote or local) the production manager
- planning and re-planning the activity in order to optimize the process of production.

To realize these services, a prototype has been implemented.

The benefits are: the reduction of costs for Re-CAD and Re-CAM operations, the reduction of time for Re-CAD and Re-CAM operations, optimization of production process, same user interface for programs and re-qualification of the operator of the CNC.

ICCOC URL: <http://aguirre.dsi.unifi.it/~hpcn/wwwiccoc/wwwpag.html>



The presence of CNC for controlling MTs has also provided the support for implementing complex strategies and thus for building specific MTs such as Milling Machines, MMs, for templates. These are strongly complex and completely re-configurable machines mainly devoted to make unique pieces with high precision of finishing on the machine. MMs for templates have to change, as fast as possible, their working program for each piece. Moreover, the description of these templates in terms of working program is very heavy since they must be produced with a high precision and this lead to have very large working programs -- e.g., several tenths of megabytes. Precision, also means to have very specialized and costly MMs. The pieces are defined on CAD/CAM stations but their design must be frequently customized changing shape, and CAM parameters. This need leads to a heavy exploitation of CAD/CAM stations for small and MMs-related issues that are in many cases very far from the CAD/CAM user mind-set. For these reasons, some builders have decided to integrate on CNCs for MMs also operations partially performed on CAD/CAM stations; but their functionality are very far from those of a full CAD or CAM.

In the enterprises, which base their economy on producing templates, it is necessary to reduce as much as possible the time during which the machine does not work -- i.e., from the working of a template to the next one -- the so called *dead time* of MM. These enterprises usually adopt a workstation for the production of the template design on a CAD. The CAD design generation involves many man-hours and has as goal a mathematical description of the mechanical model. On the basis of the output produced by the CAD, the so called CAM module generates the working program (often under neutral form), for example neutral ISO (where some information are lacking and others need to be modified). This activity of modifying and fitting is implemented according to the MM technical information: (i) the size of tools, (ii) the machine structure (as number of axes, relationships among axes, moving modalities, etc.) and according to quality and final finishing up requirements of the part same. In particular, the commercial CAMs are capable to produce working programs in neutral form, on the basis of a CAD design and some technical information. These are independent from the kind of MM and from the shape of the rough part from which the template will be obtained. This makes the CAD/CAM outputs (Neutral ISO, NISO) totally independent on details of the MT and on the dimension of the coarse piece.

To resolve this gap, CNCs builders have the duty to fit the neutral program to the various controllers and to the various MMs through fitting up program (sometimes called post processor or adaptation process). For this purpose the CAM output is provided with a set of adaptation programs, one for each type of MM which is present in the plant. So the CAM adaptation activity must be repeated for each MM, it is often necessary to repeat it for each part since the working program can change also according to the size and shape of the coarse piece of metal from which will be obtained the template. A different material removal involves a different tool path. It is also worth saying that the operator, who works at the CAD/CAM station, often does not know on which MM it will be implemented the template he/she is designing. MMs are usually very specific and hence each of these is substantially different from the other (at least as regards the same workshop) with respect to geometrical characteristics, tools, working velocity, etc. Such sizes are fundamental for obtaining the working program in the definitive form. Therefore, the MM selected influences the operations for customizing the ISO working program, to modify it according to technical characteristics of the MM and for considering the dimension of the coarse piece. In order to save dead time, the activity of adaptation should be specifically required by the CNC a short time before executing the working program in final form.

If the CNC is based on a computer with enough power, a possible way to work consists in executing the CAM and adaptation processed by the operator on the CNC itself. In this case the operator describes the actions to be performed by the MM starting from the paper version of the design produced by the CAD with the support of suitable tools. This method is pertaining to programs that are referring themselves to plane geometry parts that compose the solid. For example, the CNC user might need to carry out a



working on a template in order to change a part of it. This kind of solution has been suggested in order to reduce the time needed for reporting the modifications directly on the CAD/CAM station by using CAD/CAM personnel. In fact, when a small modification is needed its execution on the CAD/CAM station is a very time consuming task for both CAD/CAM and CNC operators. This solution has been proposed by CNC builders as a technological evolution compared to the previous one (since it is possible only on machines having high performances CNCs). On the other hand, it involves greater costs for the machines, which have to provide the necessary power to control MM and to execute CAD/CAM activities in short time. This functionality could be considered as a further possibility to be used when the working program generation is not conform with the requirements and it is necessary to re-execute both CAM and adaptation phases.

On the contrary, to make the modifications on the mechanical pieces directly on the MT leads to provoke a gap between CAD/CAM descriptions, documentation and the obtained template. The control process and thus the feedback needed for increasing quality is broken. Moreover, this type of solution has been also used for the lack of a true integration and quick communication between the machines tool department and that where CAD, CAM and adaptation phases are carried out.

ICCOC URL: <http://aguirre.dsi.unifi.it/~hpcn/wwwiccoc/wwwpag.html>

Integration between CNCs

Since long time, in the literature, various low-level communication support have been provided -- e.g., Ethernet, Token Ring, Token Bus, FDDI, ATM, BITBUS, CAN, BACnet, CEBUS, etc. Some of these are typically used for transferring data -- Ethernet, Token Ring, Token Bus, FDDI, ATM, etc... - while the other for control -- BITBUS, CAN, BACnet, CEBUS, IEEE-488, ISP, Lonworks, WorldFIP, ProfiBUS, InterBUS, etc. To this purpose, in literature various protocols for real time distributed systems management there exist.

Despite to the above experiences, the most important CNC builders make possible the interconnection of MTs with a machine playing the role of production supervisors through serial connections or "ad hoc" solutions. It should be noted that the adoption of local networks is not commonly diffuse for implementing DNC policy. Siemens proposes in its catalogue a network based on Ethernet IEEE 802.3 (CSMA/CD) 10 Mbits, which allows to connect several CNCs; it has furthermore defined a high level protocol (SINEC). Bosch allows the implementation of DNCs by connecting CNCs having interfaces with EDNC, LSV2 protocols, or the simplified RS232 and RS-422; furthermore PROFIBUS - Field Bus processor standardized according to DIN 19245 standard- is used for data exchange among PLC, also of various producers. NUM (France), FIDIA (Italy), SELCA (Italy), FANUC (Japan), GRUNDIG (Germany), DAIMLER-BENZ (Germany), and ELEXA itself (the coordinator of this project) use Ethernet 2 Mbytes for communicating among CNC with similar results as better explained in the following. As a conclusion, only low bit rates or unreliable supports have been used. This way to work corresponds to the state of the art of the interconnections among machine tools in industrial environments. These communication mechanisms are frequently used for both controls and data, also for establishing a connection between machine tools and CAD/CAM area.

Integration between CAD/CAM and MT areas.

In a typical enterprise, there are usually M MTs, M/2 workstations for CAD and M/2 machines for the execution of CAM and Adaptation applications. The MTs are furthermore supported by robots for charging and discharging pieces and tools from automated storage platforms. These automatic systems of support are usually controlled by the CNC of the MT served. In the working area also Measuring Machines, MEMA, on which templates and final pieces are measured to evaluate the conformity with the starting requirements and hence to validate the template production are present. Template measures are usually checked on the basis of a paper version of the piece. The state of the art about the communications between the CAD/CAM/adaptation environment and the area in which are located MTs/MMs for measuring and producing pieces is carried out off-line through magnetic supports. Only seldom there exist enterprises in which a network support is used to transfer working programs through FTP. Some of the CNC builders mentioned in the previous section provide a network only for distributing control by using low band networks and not for transferring to CNCs large quantities of data. This is mainly due to the fact, that a large part of MTs are used for production where the same working program is executed several times before to pass to a new one. This is confirmed by the fact that they are using Ethernet support.

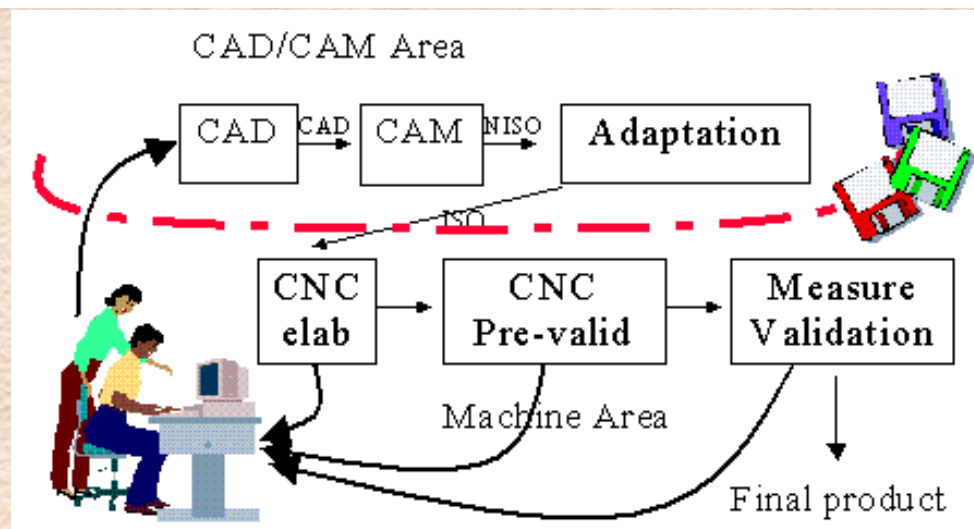

In the industries producing templates, there exists a strong interest in the integration of CAD/CAM with the factory part in which MMs, measurement systems, robots, etc., are present. The integration must be supported by a fast and reliable communication between these two areas for making available

- i. in real time working programs directly on CNCs without transferring them by using magnetic supports or by using slow and unreliable networks,
- ii. the possibility of the remote execution of CAD/CAM/adaptation directly on the CNC console.

The execution of CAD/CAM applications on MM consoles must be supported by mechanisms for dynamic optimization of CAD, CAM and MMs resources.

The same network could be used for delivering commands that are typical of CIM policy (monitoring and planning activities carried out by machines). By using a such network support and general services the CIM policy can be expanded to plan also the CAD/CAM/adaptation activities.

The above mentioned requirements seem to be contradictory since the transferring of working programs in short time (from the CAM and adaptation stations to CNC) needs a high throughput, while the sending of commands in real time (synchronization commands, alarms, etc.) means high reliability and predictability.

It is in our opinion that these problems can be solved by adopting a fast and reliable supports based on a priority based protocol such as 100VG, ATM, etc. Even Fast Ethernet (100 BT) if it is carefully used. These are typically problems solvable with HPCN technology. Other networks or control networks are less predictable or too slow (CAN, Token Ring, Lonworks, WorldFIP, PROFIBUS, etc.).

Very few CNCs builders are experiencing communication networks: see the following European conferences: Asi95 (intelligent control and integrated manufacturing systems), CEBIT95 (Information and Communications Technologies Fair) ESPRIT-CIM94



(European Conference on Information Technology, Iim95 (Integration in Manufacturing and the latest SMAU, BIMU and EMO in Milan.

This ICCOC stand alone assessment has been a preparatory study only slightly related with others EC projects such as: PLENT 20723, NetCIM 9901, AITIME 9902. The above mentioned relationship is a mere concept since none of these projects study the solutions for the above described CAD/CAM and MMs areas integration problems, even if these problems are not yet solved as demonstrated by the lack of commercial product provided by CNC builders. In addition, some of the mentioned projects give for granted that these problems exist and have as aim only the definition of the information exchanged among machines. There is a relationship also with the ESPRIT projects: OSACA 6379 (Open System Architecture for Controls with Automation systems) and MOSAIC 5292 (Modular open systems architecture for industrial motion control). The main aim of these latter projects was the definition of flexible distributed architectures at system control level, without solving specific technical interconnection problems in very noisy areas such as workshops, without considering the integration problems between CAD/CAM/adaptive machines and the CNC-based machines.

ICCOC URL: <http://aguirre.dsi.unifi.it/~hpcn/wwwiccoc/wwwpag.html>

The selection of the most suitable network support was made considering high throughput in critical conditions, physical layer, technology, drivers and development software availability.

Ethernet (IEEE 802.3), Token Ring (IEEE 802.5), Fast Ethernet 100Base-T (IEEE 802.3U), ATM, FDDI, 100VG-AnyLAN (IEEE 802.12) have been evaluated.

Among the mentioned network supports the 100VG and the 100BT have been the most interesting for the performance/cost ratio. ATM and FDDI are too expensive, this is due to the needs of fiber cables and special HUBs. 100 VG AnyLAN is more reliable than 100 BT. In certain conditions even 100BT can be profitably used (bandwidth required £ 40 Mbps and the communication are mainly 1:1). In some special conditions, when high throughput must be guaranteed, specific switches HUB can be used. Most of the tests that have been performed on the network can be replicated on both the supports with minor changes. The operations of remoting, ftping, etc. can be performed on the basis of TCP/IP protocol that is totally independent from the network support used. The previously mentioned facts place the basis for using both network supports. 100 VG and 100 BT uses the same category 5 cables and they have quite the same response to the noise when the Switch HUB is used for 100 BT. HP has decided to remove from the market the 100 VG, it is probable that others 100 VG vendors will increase its price on the market. This will make more interesting the solution based on 100 BT in the next months.

[For the tests, a network based on 100VG connected to a 10BT has been used.](#)

The network topology and hardware (wirings type, board models, HUBs, etc.) adopted for the ICCOC project consists in a 100VG HUB connected to several CNC/MM, CNC/MEMA, and CAD/CAM stations having 100VG network adapter and a bridge toward 10Base-T thin Ethernet HUB connected to Unix station (without the 100VG Adapter).

For the Remote execution of CAD/CAM/Applications the best solution seems to be the Remote Window Server Terminal Base. UNIX possesses functions that re-direct the flows of the applications towards a new terminal on the network. For Windows NT, independent software manufacturers have commercialized terminal substitutive (X-Win, X-Win32, Window Based Terminal Server, etc.).

For the file transfer the standard FTP is strongly diffuse and easy to understand, so this is the protocol chosen.

For the Production Process Optimization (monitoring the factory activity and optimizing resources according to simple schedule mechanisms and considering the status of a database containing specific information) the best solution seems to be the Intranet Technology Specific Application. Several intranet techniques for building applications have been proposed.

For the Remote execution of CNC, the full remote control (software applications that allow to remotely acquire the total control of the session excluding the original customer: PC Anywhere, Laplink) or Intranet Technology Specific Application seems to be the better solutions.

Several tests have been performed in order to verify the response in bandwidth and the CPU Utilization during the various tests, for the 100VG network connected to a 10Base-T network for interfacing with a Unix Workstation that provides the CAD and CAM programs. The using of a 10Base-T network for the remoting of the CAD does not limit the results, because, like the tests will



demonstrate, the load generated by the remoting is so low that a standard ethernet is sufficient.

In the tests, the typical conditions of the manufactures analyzed have been simulated and the typical operations have been performed. The requirements have been evaluated in an environment rich of electromagnetic noise at TECMA, that plays the role of a typical hand-user in the ICCOC project, in order to create the worst case conditions. In order to create base workload, a couple of programs named NETSERVE (server program) and NETPERF (client program), running under Windows NT, have been used. These programs generate traffic on the HUB (<http://www.netperf.org/netperf/NetperfPage.html>). The running of the above-cited programs on one, two and three couples of CNC stations generates the traffic. The stations that are not used to perform such operation are devoted to test and measure network load. The measure of the load on the HUB is performed by a program provided by HP that requires that the measuring WS is connected to the debug port of the HUB with an RS232 cable.

Referring to the prototype (mock-up), it has been capable of testing the most important features identified before, it must be integrable in the final environment consisting of a set of workstation with both Windows NT and Unix OS. For the development of the prototype, the object-oriented technology has been used. In particular the object-oriented methodology for system development has been used. At level of Management, the methodology of DSI and ELEXA has been applied.

ICCOC URL: <http://aguirre.dsi.unifi.it/~hpcn/wwwiccoc/wwwpag.html>

The Network

The network topology that has been adopted for the ICCOC project consists of a 100VG HUB connected to several CNC/MM, CNC/MEMA, and CAD/CAM stations having a 100VG network adapter and a bridge toward 10Base-T thin ethernet Hub connected to Unix station (without the 100VG Adapter). The topology is presented in the following figure.

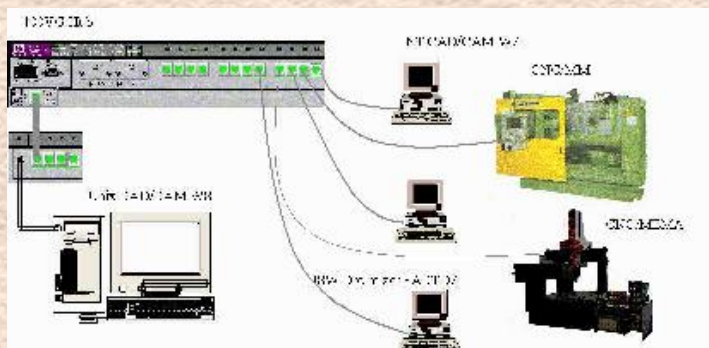

[Click here or on the image to see a bigger image more detailed \(44K\)](#)

The hardware components used for the 100VG network used are summarized in the following table.

Hub	HP J2415A - AdvanceStack 100VG Hub-14
Bridge	HP J2414B HP 100VG/ET SNMP/Bridge Module
Transceiver	HP J2608 ThinLan
Network Adapter	HP J2585B DeskDirect 10/100VG PCI LAN Adapter
Cables	UTP Cat. 5
Connectors	RJ-45

The other components are a classical 10Base-T HUB with both RJ-45 and BNC connectors connected to the Bridge Transceiver of the 100VG Hub, the internal network adapter of the Unix WS connected to the 10Base-T Hub with a Thin coaxial with the standard BNC connector.

The Mock-Up Prototype

A mock-up prototype (also called FACTO) to validate the assumption made was implemented. It consists in a distributed application designed and implemented by using object oriented technology, in particular the object oriented methodology for system development will be used. At level of Management, the methodology of DSI and ELEXA will be applied.

The main tasks the prototype accomplish are:

1. Activation of the remote execution of CAD/CAM/Adaptation workstations on CNC and MEMA machines.
2. Activation of file transfer from the machine containing the file(s) and that which has to used it.
3. The possibility of Monitoring and Measuring in real-time the activity of the factory and that of its components.
4. The possibility of Planning and Re-Planning in real-time of the activities of CAD, CAM, Adaptation workstations, CNC and MEMA machines.

The two last points are based on the assumption of building a FACTO Server to organize schedule and make the all services that are available on the network to the several Clients. For these reasons, FACTO can be considered a sort of mechanism for virtualizing the services that are available on the network. The FACTO Server could be located in a machine dedicated to its execution. The Clients are located on CAD/CAM/Adaptation Workstations, on CNC, and on MEMAs. The ICCOC prototype can be considered the early demonstrator of FACTO architecture comprised of a Server and a set of possible Clients.

FACTO provide an User Interface for:

- FTP sessions. It is the basic network operation in CNC environment. Prototype grants:
- Commands simplification: Ftp transfer requires a rigid command succession that can be totally automated to allow working time saving.
- Security: prototype, by automatic localization and transfer, grants a selective access to files and directories to assure safety of other CNC operations.

Start CAD, CAM and measurement software remote operation: Prototype would open the remote session in the available network host by a simple button click.

Facto Client and an active CAD session
on a running CNC. ([Click here on on the image to see a more detailed one](#))





Facto Client and an active CAD session on a running CNC with a performance monitor in execution. ([Click here on on the image to see a more detailed one](#))

The main results obtained by the prototype are that remoting UNIX applications on Windows NT is quite simple by using one of the several products for remoting X Terminal on Windows NT. Remoting Windows NT Applications on Windows NT can be done in several manners -- e.g., by using PCAnywhere, LapLink. By using the Window Based Terminal Server (the so called Hydra) which is currently under beta-test and will be included into the Windows NT 5.0 for Servers. Moreover, remoting Windows NT Applications on UNIX is possible by using special applicative programs, and also remoting UNIX applications on UNIX is not a problem by using X terminal.

Referring to the file transfer, this is really simple since all UNIX and Windows NT machines can used FTP based on TCP/IP.

FACTO is a prototype for future operations like:

- Automatic optimization of resource with a real time scheduling algorithm.
- Monitoring in real time of all task time and of all working deadlines.

In order to realize FACTO Java 1.1.4 of SUN Microsystem has been adopted. Java has been selected among the most diffused language for the features it can collect:

- Java is easy to learn and easy to use;
- Java is Object Oriented;
- Several Just in Time Compiler are available to compile the code in native microprocessor code machine;
- Java is portable over a large number of different platforms, and in particular under most diffuses Unix and Windows NT: WS using different operating systems can use the same server program without modification.
- Java has several native classes for supporting distributed systems Remote Method Invocation (RMI) and interface Object Request Broker (ORB) for the accessing to Object Oriented Databases. These features have permitted to create on the server object which methods are executed directly by the clients.
- Java can execute code in native language (like C++) thanks to JNI. In Windows NT JNI allows the interface between Java and C++ DLL that can run native 32 bit applications.

In the Test of Prototype, the prototype and its functionality has been tested. It includes the verification of performance of the network when it is used for remote execution of applications and for transferring large amount of data (such as working programs).

It is very important to measure both bandwidth used on the 100VG HUB and CPU Utilization for CNC Workstations during the execution of the various tests in order to verify the feasibility of operations.

In the test of the Remote execution of the UNIX CAD and visualizing its GUI on ELEXA-CNC, under different three base workload conditions (0, 40 Mbps and 68.4 Mbps), the Unix CAD is remoted on a CNC station, while another CNC station measures the load on the 100VG network. During the remoting of the application the increase in CPU Utilization for CNC is monitored in order to verify the load on the station during the normal future operation.

In the test of the Remote execution of the UNIX CAM with rendering and visualizing its GUI on ELEXA-CNC, under the previously cited different base workload conditions, the Unix CAM is remoted on a CNC station, while another CNC station measures the load on the 100VG network. During the remoting of the application the increment in CPU Utilization for the CNC is monitored in order to verify the load on the station during the normal future operations.

In the Tests about the Possibility of Remotely Control CNC from another CNC (sometimes it's necessary that a single operator controls more than one CNC; in order to allow this mechanism it's necessary to remote the console of a CNC on other CNC), the bandwidth necessary to perform such an operation, and the cost, in term of CPU utilization both for client and server CNC, are measured.

In the test about the Transferring Files, we performed a file transfer between two NT workstations and in particular from CNC/MM to CNC/MEMA station. In a second test the files are transferred between a couple of stations M1, M2. At the same time M1 requests files from M2 and M2 requests file from M1. The test are made via Unidirectional FTP and via Bi-directional FTP.

In the tests about the Possibility of Measuring, Planning and Re-Planning, we adopted different workloads on the network simulated by:

- Activation of the remote execution of the CAD;
- Activation of the remote execution of the CAM;
- Activation of the remote execution of an FTP;
- Testing of the client-server architecture of the prototype when several clients are open and operate on the same data;
- Testing of the client-server architecture of the prototype when several clients are open and operate on different data.

By the report of the result we found that:

- The load of the Prototype on the network can be neglected with respect to the other loads
- Remoting is feasible and cheap
- Is also well considered by End Users
- Network support chosen is adequate
- Real economical benefits have been detected by end users



Comments about FTP sessions

This test demonstrates that about 6 bi-directional FTP session can be activated at the same time without collapsing the network.

ICCOC URL: <http://aguirre.dsi.unifi.it/~hpcn/wwwiccoc/wwwpag.html>



The project has been completed and the work performed has demonstrated the faithfulness and the strong interest of such a product.

This opinion is shared by TECMA and from other contacted end users.

The solutions adopted in the mock-up prototype, implemented for the ICCOC project, can be profitably adopted as tested on the field. We found that:

- Remoting is feasible and cheap
- Remoting Is well considered by End Users
- Network support chosen is adequate
- Real economical benefits have been detected by end users

The benefits evaluated are:

- [Reduction of dead time for Re-CAD and Re-CAM: 60%](#)
- [Optimization of production process: saving 20%](#)
- [Re-qualification of CNC operators](#)

Thus a New Product and a New Market will be set.

The key elements for building new products and for going towards an actual integration of the factory are:

- [Remote execution of CAD, CAM, ADP, on CNC/MM and CNC/MEMA](#)
- [Monitoring the activity of the factory](#)
- [Planning and re-planning the activity in order to optimize the process of production.](#)

So the aspect of Islands integration (MTs/MEMAs/Robots) and CAD/CAM/CNC integration must be integrated.

The ICCOC project has been focussed on CAD/CAM/CNC Integration.

The whole view is going to be obtained by merging the results of ICCOC with those obtained by ELEXA on Islands.

The Costs for the real implementation of the mock-up prototype have been estimated about 900 d/m (concretely predicted on the basis of ICCOC feasibility study 15 classes x 3 x 20 days)

The above opinions are shared by TECMA and from other contacted end users: OMCS, B-Ticino, BVA, Cevolin, CB-Ferrari CALP, SL, IMES MPT, Lucchese Stampi Zago, SMP

Several other demonstrations are planned in order to verify if the requirements collected by visiting the end users have been correctly interpreted



On The Basis of the Early Prototype some Concrete Agreements for implementing ISLANDs including ICCOC capabilities: FABOHA (Germany) ELSATECH (Italy) ZAGO (Italy)

This work will place also the basis for studying suitable policies for optimizing the exploitation of resources of the factory (CAD, CAM, CNCs, etc.: a distributed application for optimizing the exploitation of the resources in the factory: Measuring, Planning and Re-Planning in real-time of the activities of CAD, CAM, Adaptation workstations, CNC and MEMA machines..). The implementation of the algorithms of resources optimization and managing could be the subject of a bigger proposal and project in the same applicative domain.

Distributed application for optimizing the exploitation of the resources in the factory: Measuring, Planning and Re-Planning in real-time of the activities of CAD, CAM, Adaptation workstations, CNC and MEMA machines.

ICCOC URL: <http://aguirre.dsi.unifi.it/~hpcn/wwwiccoc/wwwpag.html>

The consortium includes 3 Partners:

HPCN technology consumer  ELEXA

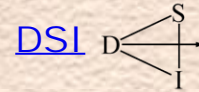

[University of Florence](http://www.dsi.unifi.it)

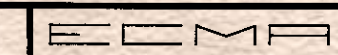

Technology provider

End user  TECMA

ICCOC URL: <http://aguirre.dsi.unifi.it/~hpcn/wwwiccoc/wwwpag.html>



ELEXA S.r.l.

(prime contractor, HPCN technology consumer)

Via delle Panche, 38 A, I-50141, Firenze, Italy

Contact Person: Marco Perfetti

Phone: +39-55-43.51.19

Fax: +39-55-43.76.334

E-mail: elexa@tin.it

DSI (Department of System and Informatics)

(HPCN Technology provider)

University of Florence, Via S.Marta, 3 A , I-50139 Firenze - ITALY

Contact person: [Paolo Nesi](mailto:nesi@dsi.unifi.it)

Phone +39 55 47.96.523

Fax: +39 55 47.96.363

E-mail: nesi@dsi.unifi.it

WWW: <http://www.dsi.unifi.it/~nesi>

TECMA S.r.l.

(End user)

Viale XX Settembre, 78

50019 Sesto Fiorentino, Firenze, ITALY

Contact person: Massimo Giorgetti

Phone: +39-55-44.42.41

Fax: +39-55-44.42.41

ICCOC URL: <http://aguirre.dsi.unifi.it/~hpcn/wwwiccoc/wwwpag.html>

TTN HPCN TETRApc

For the ICCOC activity, the partners have chosen to select TTN-TETRApc as their ``reference TTN'' that proposed by CPR (Consortium Pisa Ricerche, Pisa, Italy), CESVIT and CSM. In particular, CESVIT High-Tech Agency (a no-profit agency) has been selected by ICCOC partners as the reference TTN-TETRApc site.

It should be noted that CESVIT for TTN-TETRApc activity collaborates with the Department of Systems and Informatics (DSI partner) which provides support about the technological and scientific aspects of TTN HPCN. This collaboration is very suitable since the complementary roles of CESVIT and DSI within TTN HPCN have been well-identified. CESVIT has a very high visibility and sensitiveness with respect to the market, for distribution, advertising, evaluation, etc. activities (very useful for the management of the TTN-TETRApc), while DSI provides know-how in HPCN technologies (see the enclosed bibliography and biographies, Annex 4). According to the cooperation agreement between CESVIT and DSI for the TTN-TETRApc, the scientific responsible of the CESVIT part of TTN-TETRApc is Dr. Ing. P. Nesi of DSI. Please note that he is also the coordinator of the present activity.

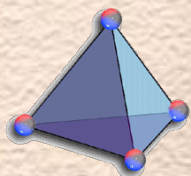

[TTN HPCN TETRApc](#)

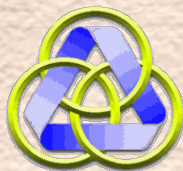

[Consorzio Pisa Ricerche](#)



ARTIC



[CESVIT](#)

ICCOc URL: <http://aguirre.dsi.unifi.it/~hpcn/wwwiccoc/wwwpag.html>

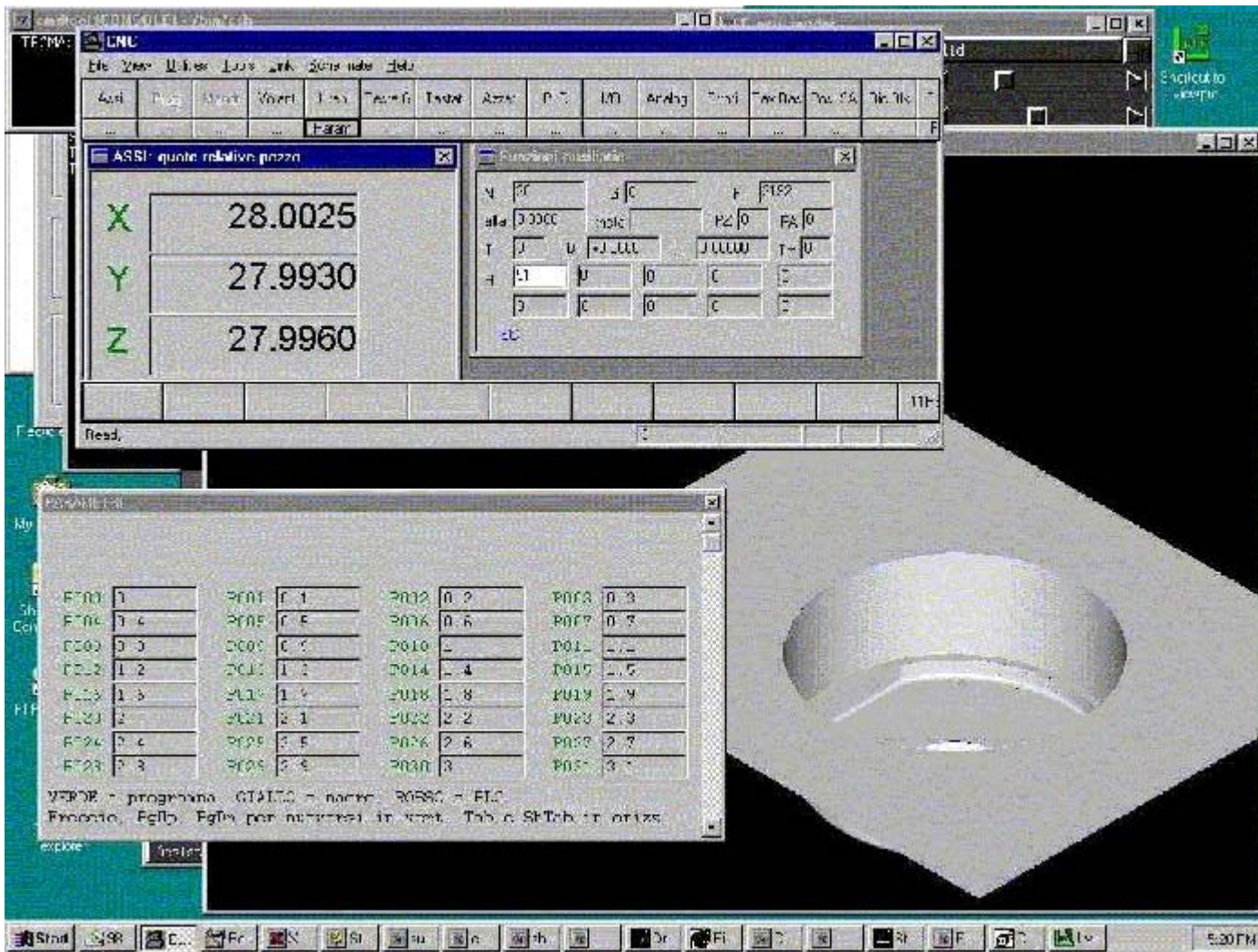

CAD remote session

IN CAD File: \\progetti\febbraio\cad2346p3

OUT CAD File: \\progetti\febbraio\cad2348.dwg

CAD Station: CAD2

OK Cancel

The CAD button allows you to select the CAD station that has to run the remote session, the input and output file.

CAM remote session

IN CAM File: \\progetti\febbraio\cam2348.igs

OUT CAM File: \\progetti\febbraio\cam2348.iso

CAM Param. File: WCNC1\lista_utensili

CAM Station: CAM1

OK Cancel

The CAM button allows you to select the CAM station that has to run the remote session, the input and output file and the parameter file for CAM generation.

Adaptation remote session

IN ADP File: \\progetti\febbraio\cam2348.iso

OUT ADP File: \\progetti\febbraio\cam2348.isn

ADP Param. File: WCNC1\lista_utensili

ADP Station: ADP

OK Cancel

The ADP button allows you to select the Adaptation station that has to run the remote session, the input and output file and finally the configuration file that contains all the information about tools that are present on the CNC station.

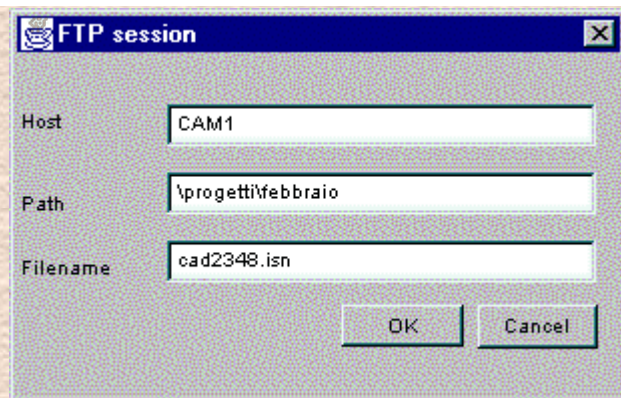

Host: CAM1
Path: \\progetti\\febbraio
Filename: cad2348.isn
OK Cancel

The FTP button allows you to transfer automatically the needed file to the CNC station in order to start the work without going around with a tape or a magnetic support.

ICCOC URL: <http://aguirre.dsi.unifi.it/~hpcn/wwwiccoc/wwwpag.html>

FACTORY INTEGRATION: CAD/CAM ON MACHINE TOOLS

ELEXA & TECMA

ICCOC project has demonstrated the possibility of integration of CAD/CAM functionality on CNC-based machines by means of HPCN technology. The integration of CAD/CAM allows the reduction of costs related to non-planned CAD/CAM activities of at least 35 %. Milling Machines, for making templates are typically used for producing unique and special templates. These usually need several CAD/CAM remakes on the basis of the machine adopted, on the machine configuration, and on the shape of the coarse piece from which the template is obtained. These facts and the lack of integration between CAD/CAM and MMs areas cause large problems of delay. The main result has been to pose the basis of implementing a new category of products for integrating CAD/CAM and MMs areas obtaining an optimal exploitation of resources. This has allowed the opening and the conquer of a new market, and as well as the consolidation of the present market.

This activity was carried out under the TETRApc TTN. TETRApc can be contacted by email (nesi@dsi.unifi.it, nesi@ingfi1.ing.unifi.it) or by telephone (+39-055-4796523) or FAX (+39-055-4796363). The initial contact is Paolo Nesi.

-----detailed version-----

ELEXA is builder of CNCs for milling machines and robots of CB Ferrari (one of the most important European Milling Machine builder). TECMA is a factory for template production.

Typically, a center of production (an island of production) is comprised of several milling machines, one or more robots, a measuring machine. The islands are only slightly connected with CAD/CAM area. The typical Milling Machines produced are mainly used for producing small series of templates. This type of production is very specific since templates have to be considered unique pieces for which the precision and the finiteness degree are really critical. The process of refinement includes phases in which CAD, CAM and milling are iterated.

Presently, communications and relationships between CAD/CAM and the CNC area are mainly carried out by using humans carrying foils and messages. In the most competitive solutions file transfer is used; but it doesn't solve the problems of integration. Changes on CAD, CAM files have to be made on CAD/CAM area and the two areas are physically located very far to each other. This fact leads to have high costs for making corrections on CAD/CAM phases in the production process. ICCOC: Integration of CAD/CAM Operations into a CNC-based (Computerized Numerical Control) Machine.

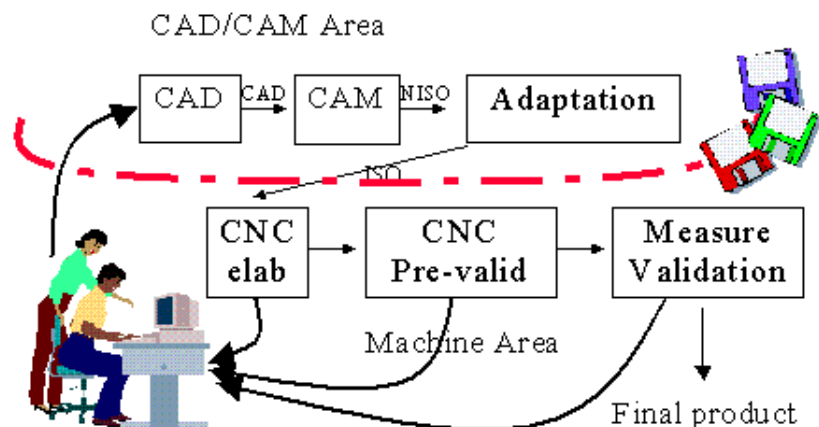

THE SOLUTION

The ICCOC project consists of a feasibility study to assess the possibility of the integration of CAD/CAM functionality on CNC-based machines using HPCN technology. The main idea is to adopt a fast, reliable, noise-robust network to execute CAD/CAM applications on remote CNC machines and to optimize exploitation of the resources present in CAD/CAM and Milling Machine areas.

The result of ICCOC feasibility study is the profile of the main aspects of a new product for optimizing processes of production and integrating the factory resources: reduction of time for changes in CAD/CAM phases, reduction of time for validating pieces, optimization of production costs, and improvement of factory integration and quality management.

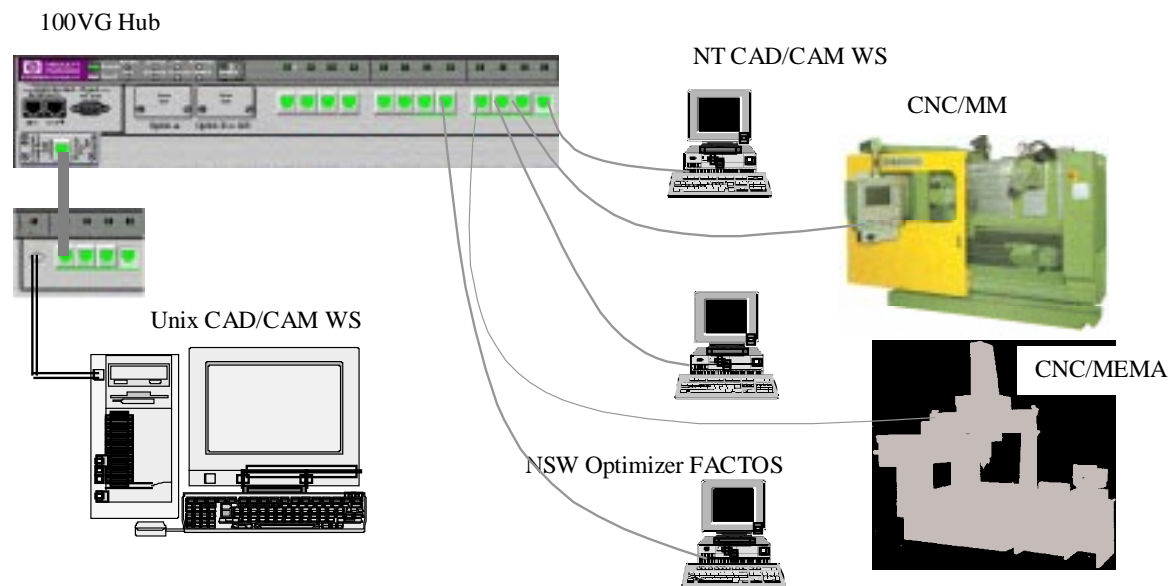

These goals can be achieved by using the support of these four main components:

- Remote execution of CAD/CAM/Adaptation workstations on CNC and measuring machines;
- File transfer from the machine containing the file(s) and that which has to use it;
- Monitoring and Measuring in real-time the activity of the factory and that of its components;
- Planning and Re-Planning in real-time the activities of CAD, CAM, Adaptation workstations, CNC and measuring machines;

The execution of CAD/CAM applications on MM consoles must be supported by mechanisms for dynamic optimization of CAD, CAM and MMs resources.

The same network could be used for delivering commands that are typical of CIM policy (monitoring and planning activities carried out by machines). By using a such network support and general services the CIM policy can be expanded to plan also the CAD/CAM/adaptation activities.

The above mentioned requirements seem to be contradictory since the transferring of working programs in short time (from the CAM and adaptation stations to CNC) needs a high throughput, while the sending of commands in real-time (synchronization commands, alarms, etc.) means high reliability and predictability. It is in our opinion that these problems can be solved by adopting a fast and reliable supports based on a priority-based protocol such as 100VG, ATM, etc. Even Fast Ethernet (100 BT) if it is carefully used. These are typically problems solvable with HPCN technology. Other networks or control networks are less predictable or too slow (CAN, Token Ring, Lonworks, WorldFIP, PROFIBUS, etc.).

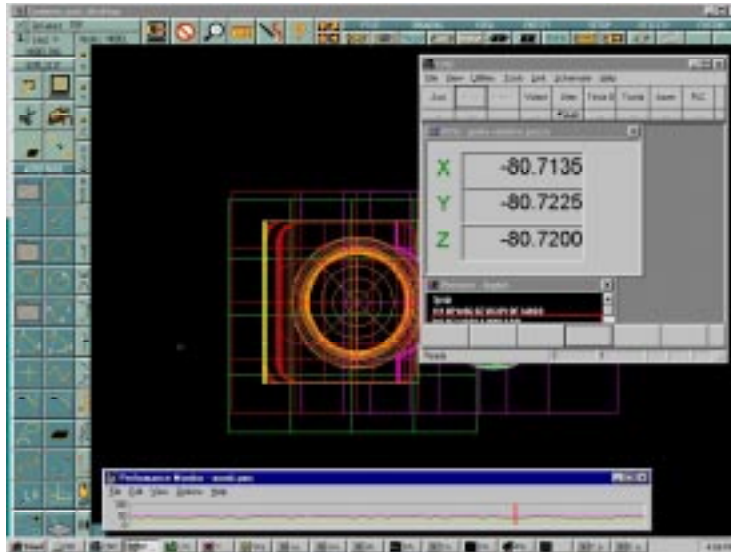

In the tests about the Possibility of Measuring, Planning and Re-Planning, we adopted different workloads on the network simulated by:

- Activation of the remote execution of the CAD;
- Activation of the remote execution of the CAM;
- Activation of the remote execution of an FTP;
- Testing of the client-server architecture of the prototype when several clients are open and operate on the same data;
- Testing of the client-server architecture of the prototype when several clients are open and operate on different data.

By the report of the result we found that:

- The load of the Prototype on the network can be neglected with respect to the other loads
- Remoting is feasible and cheap
- Is also well-considered by End-Users
- Network support chosen is adequate

Real economical benefits have been detected by end-users

THE EXPERIENCE OF TECMA

To this end HPCN technology has been used and can be profitably used for distributing the information and services along the factory. Specifically for the production process optimization: for monitoring the factory activity and optimizing resources according to simple schedule mechanisms and considering the status of a database containing specific information the best solution seems to be the Intranet Technology.

ELEXA has been supported in introducing HPCN technology into its products by DSI, Department of Systems and Informatics, of University of Florence. The prototype produced has been tested and validated by TECMA a producer of templates.

The registered industrial benefits:

- Reduction of costs for the remake of a CAD and/or a CAM phase of 60%
- Reduction of time for remake of a CAD and/or CAM phase of 20%
- Optimization of production process: saving 20%
- Re-qualification of people working on CNC

Thus a New Product and a New Market will be identified and shown. A small phase of dissemination has been drawn among factories involved in the first phase of requirement analysis of the feasibility study. From

this, as a first result, some concrete agreements for implementing integrated islands of production including ICCOC capabilities has been received.

FURTHER DETAILS:

<http://www.dsi.unifi.it/~hpcn/wwwiccoc/wwwpag.html>

For further information contact:

Adolfo Villoresi, Marco Perfetti,
ELEXA, TECMA
Via delle Panche 38A, Firenze 50100, Italy
tel: +39-055-435119, fax: +39-055-4376334
email: elexa@tin.it

This activity was carried out under the TETRApc TTN. TETRApc can be contacted by email (nesi@dsi.unifi.it, nesi@ingfi1.ing.unifi.it) or by telephone (+39-055-4796523) or FAX (+39-055-4796363). The initial contact is Paolo Nesi.



Public Final Report of ESPRIT HPCN PST Activity:

**ICCOC - Integrated CAD/CAM Operations
into CNC-based machines**



ELEXA

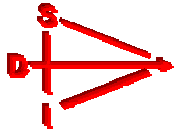

DSI, University of Florence



TECMA

Ver.1.0, 31/8/98

1. ABSTRACT

ICCOC project consist in a preliminary study for assessing the possibility of integration of CAD/CAM functionality on CNC-based machines by means of HPCN technology.

ELEXA (Project Manager and Technical consumer) builds CNCs (Computerized Numerical Controls) for milling machines, MMs, for making templates. These particular kind of machines are strongly re-configurable and are used for producing unique and special templates. These usually need several CAD/CAM remakes on the basis of the machine adopted, on the machine configuration and on the shape of the coarse piece from witch the template is obtained.

The objective of this project has been the identification of a suitable network to support the integration between the CAD/CAM area and the machine area so to allow a reliable and fast remote execution of CAD/CAM applications on MMs console concurrently to the machine control, the dynamic optimization of CAD, CAM and MMs resources, fast and reliable transferring of very large quantity of data.

2. SYNOPSIS

The objective of this project has been the identification of a suitable network to support the integration between the CAD/CAM area and the machine area so to allow a reliable and fast remote execution of CAD/CAM applications on MMs console concurrently to the machine control, the dynamic optimization of CAD, CAM and MMs resources, fast and reliable transferring of very large quantity of data.

ELEXA (the technical consumer of this project) builds Computerized Numerical Controls for Milling Machines, MMs, for making templates in unique pieces with very high precision of finishing on the machine. Templates are typically defined on CAD/CAM stations but their design must be frequently customized changing shape, and CAM parameters. This need leads to a heavy exploitation of CAD/CAM stations for considering issues strictly related to MMs, these are in turn very far from the CAD/CAM user mind-set. MMs for templates have to change, as fast as possible, their working program for each piece. Moreover, the description of these templates in terms of working program is very heavy since they must be produced with a high precision and this lead to have very large working programs -- e.g., several tenths of megabytes. Precision, also means to have very specialized and costly MMs. The pieces are defined on CAD/CAM stations but their design must be frequently customized changing shape, and CAM parameters. This need leads to a heavy exploitation of CAD/CAM stations for small and MMs-related issues that are in many cases very far from the CAD/CAM user mind-set. For these reasons, some builders have decided to integrate on CNCs for MMs also operations partially performed on CAD/CAM stations. For example, the visualization of working program (both in graphics and statements forms) for obtaining a specific mechanical piece, the implementation of coarse working programs on the basis of simple graphic editors. In the enterprises, which base their economy on producing templates, it is necessary to reduce as much as possible the time during which the machine does not work -- i.e., from the working of a template to the next one -- the so called *dead time* of MM.

The improvement of the integration between the CAD/CAM area and the Machine Tools should encompass the hereinafter aspects:

- remote execution of CAD, CAM directly on the CNCs of the Milling Machines
- transferring of files among the several workstations of the factory should be implemented by using FTP or other higher level more reliable mechanisms
- monitoring the activity of the factory
- advertising (remote or local) the production manager
- planning and re-planning the activity in order to optimize the process of production.

To realize these services, a prototype has been implemented.

The benefits are:

the reduction of costs for Re-CAD and Re-CAM operations, the reduction of time for Re-CAD and Re-CAM operations, optimization of production process, same user interface for programs and re-qualification of the operator of the CNC.

A slide summarising the results is included in Appendix A.

The ICCOC participants

ELEXA S.r.l. (prime contractor, HPCN technology consumer)

Via delle Panche, 38 A, I-50141, Firenze, Italy

Contact Person: Marco Perfetti

Phone: +39-55-43.51.19

Fax: +39-55-43.76.334

E-mail: elexa@tin.it

DSI (Department of System and Informatics) (HPCN Technology provider)

University of Florence, Via S.Marta, 3 A , I-50139 Firenze - ITALY

Contact person: Paolo Nesi

tel. +39 55 47.96.523

fax: +39 55 47.96.730

e-mail: nesi@dsi.unifi.it

WWW: <http://www.dsi.unifi.it/~nesi>

TECMA S.r.l. (End user)

Viale XX Settembre, 78

I-50019 Sesto Fiorentino, Firenze, ITALY

Contact person: Massimo Giorgetti

Phone: +39-55-44.42.41

Fax: +39-55-44.42.41

3. EXECUTIVE SUMMARY

The objective of this project is the identification of a suitable network to support the integration between the CAD/CAM area and the machine area so to allow a reliable and fast remote execution of CAD/CAM applications on MMs console concurrently to the machine control, the dynamic optimization of CAD, CAM and MMs resources, fast and reliable transferring of very large quantity of data.

ELEXA (the technical consumer of this project) builds Computerized Numerical Controls for Milling Machines, MMs, for making templates in unique pieces with very high precision of finishing on the machine. CNC is the main component of factory automation (Computerized Numerical Control), in which set of functionality can be automatically realized for the management of Machine Tools, MT. CNC-based machines, sequences of operative actions are defined by a set of instructions that are defined in the preparation phase for elaborating the selected piece of metal. Each mechanical part to be built on the machine is obtained by using a specific set of instructions (so called working program) containing all details: (i) operational actions and of (ii) machines outfit. In the working program, the sequence of operative actions is described according to a particular programming language, for example the well-known ISO (International Standard Organization). ISO programs are usually produced on a CAD/CAM (Computer Aided Design)/(Computer Aided Manufactory) workstation.

The presence of CNC for controlling MTs has also provided the support for implementing complex strategies and thus for building specific MTs such as Milling Machines, MMs, for templates. These are strongly complex and completely re-configurable machines mainly devoted to make unique pieces with high precision of finishing on the machine. MMs for templates have to change, as fast as possible, their working program for each piece. Moreover, the description of these templates in terms of working program is very heavy since they must be produced with a high precision and this lead to have very large working programs -- e.g., several tenths of megabytes. Precision, also means to have very specialized and costly MMs. The pieces are defined on CAD/CAM stations but their design must be frequently customized changing shape, and CAM parameters. This need leads to a heavy exploitation of CAD/CAM stations for small and MMs-related issues that are in many cases very far from the CAD/CAM user mind-set. For these reasons, some builders have decided to integrate on CNCs for MMs also operations partially performed on CAD/CAM stations; but their functionality are very far from those of a full CAD or CAM.

In the enterprises, which base their economy on producing templates, it is necessary to reduce as much as possible the time during which the machine does not work -- i.e., from the working of a template to the next one -- the so called *dead time* of MM. These enterprises usually adopt a workstation for the production of the template design on a CAD. The CAD design generation involves many man-hours and has as goal a mathematical description of the mechanical model. On the basis of the output produced by the CAD, the so called CAM module generates the working program (often under neutral form), for example neutral ISO (where some information are lacking and others need to be modified). This activity of modifying and fitting is implemented according to the MM technical information: (i) the size of tools, (ii) the machine structure (as number of axes, relationships among axes, moving modalities, etc.) and according to quality and final finishing up requirements of the part same. In particular, the commercial CAMs are capable to produce working programs in neutral form, on the basis of a CAD design and some technical information. These are independent from the kind of MM and from the shape of the rough part from which the template will be obtained. This makes the CAD/CAM outputs (Neutral ISO, NISO) totally independent on details of the MT and on the dimension of the coarse piece.

To resolve this gap, CNCs builders have the duty to fit the neutral program to the various controllers and to the various MMs through fitting up program (sometimes called post-processor or adaptation process). For this purpose the CAM output is provided with a set of adaptation programs, one for each type of MM which is present in the plant. So the CAM adaptation activity must be repeated for each MM, it is often necessary to repeat it for each part since the working program can change also according to the size and shape of the coarse piece of metal from which will be obtained the template. A different material removal involves a different tool path. It

is also worth saying that the operator, who works at the CAD/CAM station, often does not know on which MM it will be implemented the template he/she is designing. MMs are usually very specific and hence each of these is substantially different from the other (at least as regards the same workshop) with respect to geometrical characteristics, tools, working velocity, etc. Such sizes are fundamental for obtaining the working program in the definitive form. Therefore, the MM selected influences the operations for customizing the ISO working program, to modify it according to technical characteristics of the MM and for considering the dimension of the coarse piece. In order to save dead time, the activity of adaptation should be specifically required by the CNC a short time before executing the working program in final form.

If the CNC is based on a computer with enough power, a possible way to work consists in executing the CAM and adaptation processed by the operator on the CNC itself. In this case the operator describes the actions to be performed by the MM starting from the paper version of the design produced by the CAD with the support of suitable tools. This method is pertaining to programs that are referring themselves to plane geometry parts that compose the solid. For example, the CNC user might need to carry out a working on a template in order to change a part of it. This kind of solution has been suggested in order to reduce the time needed for reporting the modifications directly on the CAD/CAM station by using CAD/CAM personnel. In fact, when a small modification is needed its execution on the CAD/CAM station is a very time consuming task for both CAD/CAM and CNC operators. This solution has been proposed by CNC builders as a technological evolution compared to the previous one (since it is possible only on machines having high performances CNCs). On the other hand, it involves greater costs for the machines, which have to provide the necessary power to control MM and to execute CAD/CAM activities in short time. This functionality could be considered as a further possibility to be used when the working programme generation is not conform with the requirements and it is necessary to re-execute both CAM and adaptation phases.

On the contrary, to make the modifications on the mechanical pieces directly on the MT leads to provoke a gap between CAD/CAM descriptions, documentation and the obtained template. The control process and thus the feedback needed for increasing quality is broken. Moreover, this type of solution has been also used for the lack of a true integration and quick communication between the machines tool department and that where CAD, CAM and adaptation phases are carried out.

It goes without saying that the improvement of the integration between the CAD/CAM area and the Machine Tools should encompass several aspects:

- remote execution of CAD, CAM and Adaptation Programs directly on the CNCs of the Milling Machines
- transferring of files among the several workstations of the factory should be implemented by using FTP or other higher level more reliable mechanisms
- monitoring the activity of the factory
- advertising (remote or local) the production manager
- planning and re-planning the activity in order to optimize the process of production.

To verify the aspect pointed out above, a mock-up prototype has been implemented.

The benefits are:

- the reduction of costs for Re-CAD and Re-CAM operations
- reduction of time for Re-CAD and Re-CAM operations
- optimization of production process
- same user interface for programs and re-qualification of the operator of the CNC

4. FULL TECHNICAL TEXT

4.1 State of the art

One of the main objective of this project has been the identification of a suitable network to support the integration between the CAD/CAM area and the machine area so to allow a reliable and fast remote execution of CAD/CAM applications on MMs console concurrently to the machine control, the dynamic optimization of CAD, CAM and MMs resources, fast and reliable transferring of very large quantity of data.

These particular kind of machines are strongly re-configurable and are used for producing unique and special templates. These usually need several CAD/CAM remakes on the basis of the machine adopted, on the machine configuration and on the shape of the coarse piece from witch the template will be obtained. Templates are typically defined on CAD/CAM stations but their design must be frequently customized changing shape, and CAM parameters. This need leads to a heavy exploitation of CAD/CAM stations for considering issues strictly related to MMs, these are in turn very far from the CAD/CAM user mind-set. MMs for templates have to change, as fast as possible, their working program for each piece. Moreover, the description of these templates in terms of working program is very heavy since they must be produced with a high precision and this lead to have very large working programs -- e.g., several tenths of megabytes. Precision, also means to have very specialized and costly MMs. The pieces are defined on CAD/CAM stations but their design must be frequently customized changing shape, and CAM parameters. This need leads to a heavy exploitation of CAD/CAM stations for small and MMs-related issues that are in many cases very far from the CAD/CAM user mind-set. For these reasons, some builders have decided to integrate on CNCs for MMs also operations partially performed on CAD/CAM stations. For example, the visualization of working program (both in graphics and statements forms) for obtaining a specific mechanical piece, the implementation of coarse working programs on the basis of simple graphic editors. In the enterprises, which base their economy on producing templates, it is necessary to reduce as much as possible the time during which the machine does not work -- i.e., from the working of a template to the next one -- the so called *dead time* of MM.

MTs are frequently related to each other by using robots and other mechanisms for the transport of mechanical pieces, these machines can be considered the glue among MTs. Robots and other mechanisms are usually managed by the same CNC which controls the MT/MM to which they are devoted. Connection among CNCs for implementing DNC policy on wider islands are typically made by means of dedicated I/O ports, one connection for each synchronization signal. The control is usually assigned to a CNC which controls the others by using a set of commands for distributing and synchronizing operational elaborations. Thus, it is usual to have DNC systems in which the central CNC is used for planning production according to CIM. While the other CNCs executed the specific operations.

4.1.1 State of the art: integration between CNCs

Since long time, in the literature, various low-level communication support have been provided -- e.g., Ethernet, Token Ring, Token Bus, FDDI, ATM, BITBUS, CAN, BACnet, CEBUS, etc. Some of these are typically used for transferring data -- Ethernet, Token Ring, Token Bus, FDDI, ATM, etc... - while the other for control -- BITBUS, CAN, BACnet, CEBUS, IEEE-488, ISP, Lonworks, WorldFIP, ProfiBUS, InterBUS, etc. To this purpose, in literature various protocols for real time distributed systems management there exist.

Despite to the above experiences, the most important CNC builders make possible the interconnection of MTs with a machine playing the role of *production supervisors* through serial connections or "ad-hoc" solutions. It should be noted that the adoption of local networks is not commonly diffuse for implementing DNC policy. Siemens proposes in its catalogue a network based on Ethernet IEEE 802.3 (CSMA/CD) 10 Mbits, which allows to connect several CNCs; it has furthermore defined a high-level protocol (SINEC). Bosch allows the implementation of DNCs by connecting CNCs having interfaces with EDNC, LSV2 protocols, or the simplified

RS232 and RS-422; furthermore PROFIBUS - Field Bus processor standardized according to DIN 19245 standard- is used for data exchange among PLC, also of various producers. NUM (France), FIDIA (Italy), SELCA (Italy), FANUC (Japan), GRUNDIG (Germany), DAIMLER-BENZ (Germany), and ELEXA itself (the coordinator of this project) use Ethernet 2 Mbytes for communicating among CNC with similar results as better explained in the following. As a conclusion, only low bit rates or unreliable supports have been used. This way to work corresponds to the state of the art of the interconnections among machine tools in industrial environments. These communication mechanisms are frequently used for both controls and data, also for establishing a connection between machine tools and CAD/CAM area.

4.1.2 State of the Art : integration between CAD/CAM and MT areas.

In a typical enterprise, there are usually M MTs, $M/2$ workstations for CAD and $M/2$ machines for the execution of CAM and Adaptation applications. The MTs are furthermore supported by robots for charging and discharging pieces and tools from automated storage platforms. These automatic systems of support are usually controlled by the CNC of the MT served. In the working area also Measuring Machines, MEMA, on which templates and final pieces are measured to evaluate the conformity with the starting requirements and hence to validate the template production are present. Template measures are usually checked on the basis of a paper version of the piece. The state of the art about the communications between the CAD/CAM/adaptation environment and the area in which are located MTs/MMs for measuring and producing pieces is carried out off-line through magnetic supports. Only seldom there exist enterprises in which a network support is used to transfer working programmes through FTP. Some of the CNC builders mentioned in the previous section provide a network only for distributing control by using low-band networks and not for transferring to CNCs large quantities of data. This is mainly due to the fact, that a large part of MTs are used for production where the same working programme is executed several times before to pass to a new one. This is confirmed by the fact that they are using Ethernet support.

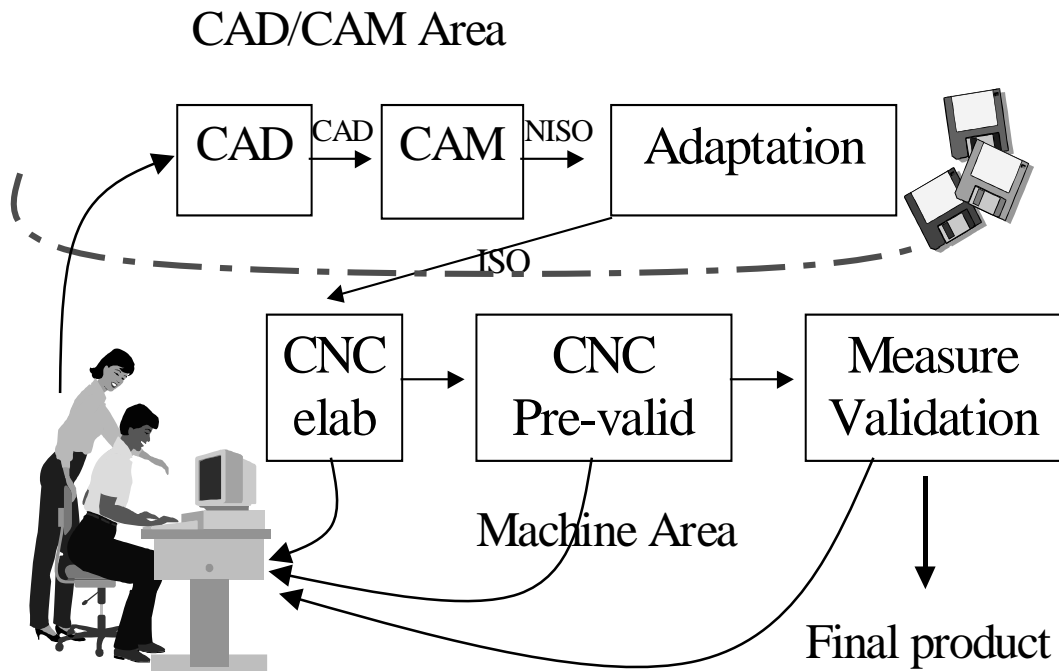

In the industries producing templates, there exists a strong interest in the integration of CAD/CAM with the factory part in which MMs, measurement systems, robots, etc., are present. The integration must be supported by a fast and reliable communication between these two areas for making available

- (i) in real-time working programmes directly on CNCs without transferring them by using magnetic supports or by using slow and unreliable networks,
- (ii) the possibility of the remote execution of CAD/CAM/adaptation directly on the CNC console.

The execution of CAD/CAM applications on MM consoles must be supported by mechanisms for dynamic optimization of CAD, CAM and MMs resources.

The same network could be used for delivering commands that are typical of CIM policy (monitoring and planning activities carried out by machines). By using a such network support and general services the CIM policy can be expanded to plan also the CAD/CAM/adaptation activities.

The above mentioned requirements seem to be contradictory since the transferring of working programs in short time (from the CAM and adaptation stations to CNC) needs a high throughput, while the sending of commands in real-time (synchronization commands, alarms, etc.) means high reliability and predictability.

It is in our opinion that these problems can be solved by adopting a fast and reliable supports based on a priority-based protocol such as 100VG, ATM, etc. Even Fast Ethernet (100 BT) if it is carefully used. These are typically problems solvable with HPCN technology. Other networks or control networks are less predictable or too slow (CAN, Token Ring, Lonworks, WorldFIP, PROFIBUS, etc.).

Very few CNCs builders are experiencing communication networks: see the following European conferences: Asi95 (intelligent control and integrated manufacturing systems), CEBIT95 (Information and Communications Technologies Fair) ESPRIT-CIM94 (European Conference on Information Technology, im95 (Integration in Manufacturing and the latest SMAU, BIMU and EMO in Milan.

This ICCOC stand alone assessment has been a preparatory study only slightly related with others EC projects such as: PLENT 20723, NetCIM 9901, AITIME 9902. The above mentioned relationship is a mere concept since none of these projects study the solutions for the above described CAD/CAM and MMs areas integration problems, even if these problems are not yet solved as demonstrated by the lack of commercial product provided by CNC builders. In addition, some of the mentioned projects give for granted that these problems exist and have as aim only the definition of the information exchanged among machines. There is a relationship also with the ESPRIT projects: OSACA 6379 (Open System Architecture for Controls with Automation systems) and MOSAIC 5292 (Modular open systems architecture for industrial motion control). The main aim of these latter projects was the definition of flexible distributed architectures at system control level, without solving specific technical interconnection problems in very noisy areas such as workshops, without considering the integration problems between CAD/CAM/adaptive machines and the CNC-based machines.

4.2 Approach

The keys of the project are: High Performance Network, remote execution of CAD/CAM Applications, file transfer, remote execution of CNC and production process optimization. One of the main aim of the project is the creation of a mock-up prototype to validate the feasibility of the project and to validate the solution chosen.

The selection of the most suitable network support was made considering high throughput in critical conditions, physical layer, technology, drivers and development software availability.

Ethernet (IEEE 802.3), Token Ring (IEEE 802.5), Fast Ethernet 100Base-T (IEEE 802.3U), ATM, FDDI, 100VG-AnyLAN (IEEE 802.12) have been evaluated.

Among the mentioned network supports the 100VG and the 100BT have been the most interesting for the performance/cost ratio. ATM and FDDI are too expensive, this is due to the needs of fiber cables and special HUBs. 100 VG AnyLAN is more reliable than 100 BT. In certain conditions even 100BT can be profitably used (bandwidth required ≤ 40 Mbps and the communication are mainly 1:1). In some special conditions, when high throughput must be guaranteed, specific switches HUB can be used. Most of the tests that have been performed on the network can be replicated on both the supports with minor changes. The operations of remoting, ftping, etc. can be performed on the basis of TCP/IP protocol that is totally independent from the network support used. The previously mentioned facts place the basis for using both network supports. 100 VG and 100 BT uses the same category 5 cables and they have quite the same response to the noise when the Switch HUB is used for 100 BT. HP has decided to remove from the market the 100 VG, it is probable that others 100 VG vendors will increase its price on the market. This will make more interesting the solution based on 100 BT in the next months.

For the tests, a network based on 100VG connected to a 10BT has been used.

The network topology and hardware (wirings type, board models, HUBs, etc.) adopted for the ICCOC project consists in a 100VG HUB connected to several CNC/MM, CNC/MEMA, and CAD/CAM stations having 100VG network adapter and a bridge toward 10Base-T thin Ethernet HUB connected to Unix station (without the 100VG Adapter).

For the Remote execution of CAD/CAM/Applications the best solution seems to be the Remote Window Server Terminal Base. UNIX possesses functions that re-direct the flows of the applications towards a new terminal on the network. For Windows NT, independent software manufacturers have commercialized terminal substitutive (X-Win, X-Win32, Window Based Terminal Server, etc.).

For the file transfer the standard FTP is strongly diffuse and easy to understand, so this is the protocol chosen.

For the Production Process Optimization (monitoring the factory activity and optimizing resources according to simple schedule mechanisms and considering the status of a database containing specific information) the best solution seems to be the Intranet Technology Specific Application. Several intranet techniques for building applications have been proposed.

For the Remote execution of CNC, the full remote control (software applications that allow to remotely acquire the total control of the session excluding the original customer: PC Anywhere, Laplink) or Intranet Technology Specific Application seems to be the better solutions.

Several tests have been performed in order to verify the response in bandwidth and the CPU Utilization during the various tests, for the 100VG network connected to a 10Base-T network for interfacing with a Unix Workstation that provides the CAD and CAM programs. The using of a 10Base-T network for the remoting of the CAD does not limit the results, because, like the tests will demonstrate, the load generated by the remoting is so low that a standard ethernet is sufficient.

In the tests, the typical conditions of the manufactures analyzed have been simulated and the typical operations have been performed. The requirements have been evaluated in an environment rich of electromagnetic noise at TECMA, that plays the role of a typical hand-user in the ICCOC project, in order to create the worst case conditions. In order to create base workload, a couple of programs named NETSERVE (server program) and NETPERF (client program), running under Windows NT, have been used. These programs generate traffic on the HUB (<http://www.cup.hp.com/netperf/NetperfPage.html>). The running of the above-cited programs on one, two and three couples of CNC stations generates the traffic. The stations that are not used to perform such operation are devoted to test and measure network load. The measure of the load on the HUB is performed by a program provided by HP that requires that the measuring WS is connected to the debug port of the HUB with an RS232 cable.

Referring to the prototype (mock-up), it has been capable of testing the most important features identified before, it must be integrable in the final environment consisting of a set of workstation with both Windows NT and Unix OS. For the development of the prototype, the object-oriented technology has been used. In particular the object-oriented methodology for system development has been used. At level of Management, the methodology of DSI and ELEXA has been applied.

In the Test of Prototype, the prototype and its functionality has been tested. It includes the verification of performance of the network when it is used for remote execution of applications and for transferring large amount of data (such as working programs).

Remote execution is one of the principal applications that will be executed on the network. In the network configuration adopted, the remoting is obtained by the use of a specific terminal programs (e.g. X-WIN Pro of LabTam Corp.) that allows the visualization of a UNIX X Terminal on a CNC, Windows NT based station.

It is very important to measure both bandwidth used on the 100VG HUB and CPU Utilization for CNC Workstations during the execution of the various tests in order to verify the feasibility of operations.

In the test of the Remote execution of the UNIX CAD and visualizing its GUI on ELEXA-CNC, under different three base workload conditions (0, 40 Mbps and 68.4 Mbps), the Unix CAD is remoted on a CNC station, while another CNC station measures the load on the 100VG network. During the remoting of the application the increase in CPU Utilization for CNC is monitored in order to verify the load on the station during the normal future operation.

In the test of the Remote execution of the UNIX CAM with rendering and visualizing its GUI on ELEXA-CNC, under the previously cited different base workload conditions, the Unix CAM is remoted on a CNC station, while another CNC station measures the load on the 100VG network. During the remoting of the application the increment in CPU Utilization for the CNC is monitored in order to verify the load on the station during the normal future operations.

In the Tests about the Possibility of Remotely Control CNC from another CNC (sometimes it's necessary that a single operator controls more than one CNC; in order to allow this mechanism it's necessary to remote the console of a CNC on other CNC), the bandwidth necessary to perform such an operation, and the cost, in term of CPU utilization both for client and server CNC, are measured.

In the test about the Transferring Files, we performed a file transfer between two NT workstations and in particular from CNC/MM to CNC/MEMA station. In a second test the files are transferred between a couple of stations M1, M2. At the same time M1 requests files from M2 and M2 requests file from M1. The test are made via Unidirectional FTP and via Bidirectional FTP.

In the tests about the Possibility of Measuring, Planning and Re-Planning, we adopted different workloads on the network simulated by:

- Activation of the remote execution of the CAD;
- Activation of the remote execution of the CAM;

- Activation of the remote execution of an FTP;
- Testing of the client-server architecture of the prototype when several clients are open and operate on the same data;
- Testing of the client-server architecture of the prototype when several clients are open and operate on different data.

By the report of the result we found that:

- The load of the Prototype on the network can be neglected with respect to the other loads
- Remoting is feasible and cheap
- Is also well-considered by End-Users
- Network support chosen is adequate
- Real economical benefits have been detected by end-users

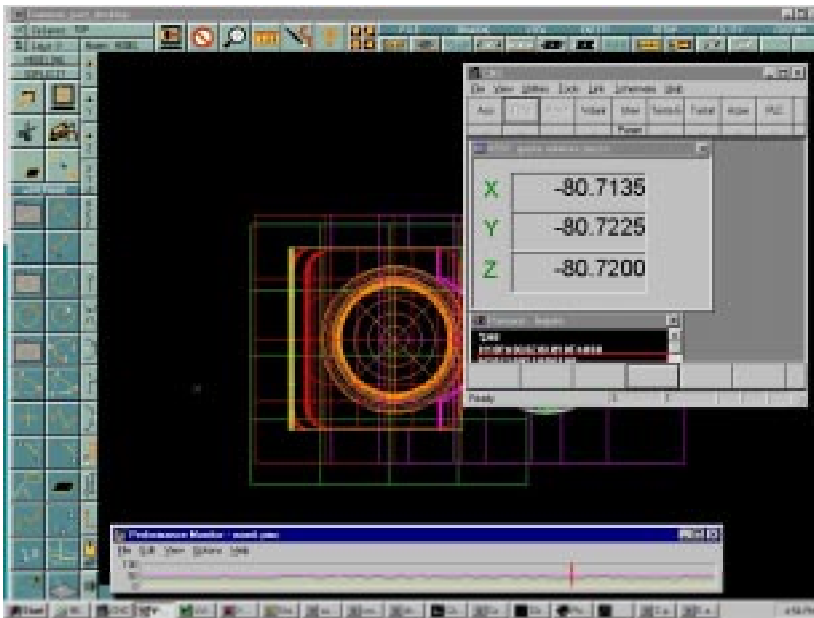

The figure reports a CNC station in which the remote execution of a CAD application has been activated. On the bottom of the figure, the status of of the task monitor of windows NT has been also reported in order to show the load of the workstation.

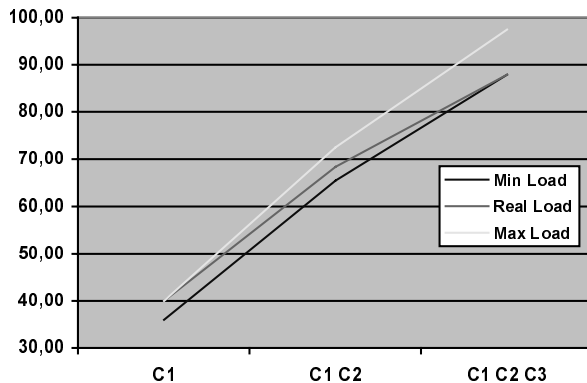

The figure reports the load of the network. In order to measure the effective performance, three couple of machines have been tested separately so to evaluate the maximum load on the HUB. The HUB has been guaranteed to have at least 90% efficiency under any workload conditions. C1, C2, C3: the three couples versus the load shown in Mbps.

4.3 Results

In this paragraph are summarized the main results, achievements and benefits obtained by this project.

4.3.1 Network

The network topology that has been adopted for the ICCOC project consists of a 100VG HUB connected to several CNC/MM, CNC/MEMA, and CAD/CAM stations having a 100VG network adapter and a bridge toward 10Base-T thin ethernet Hub connected to Unix station (without the 100VG Adapter). The topology is presented in the following figure.

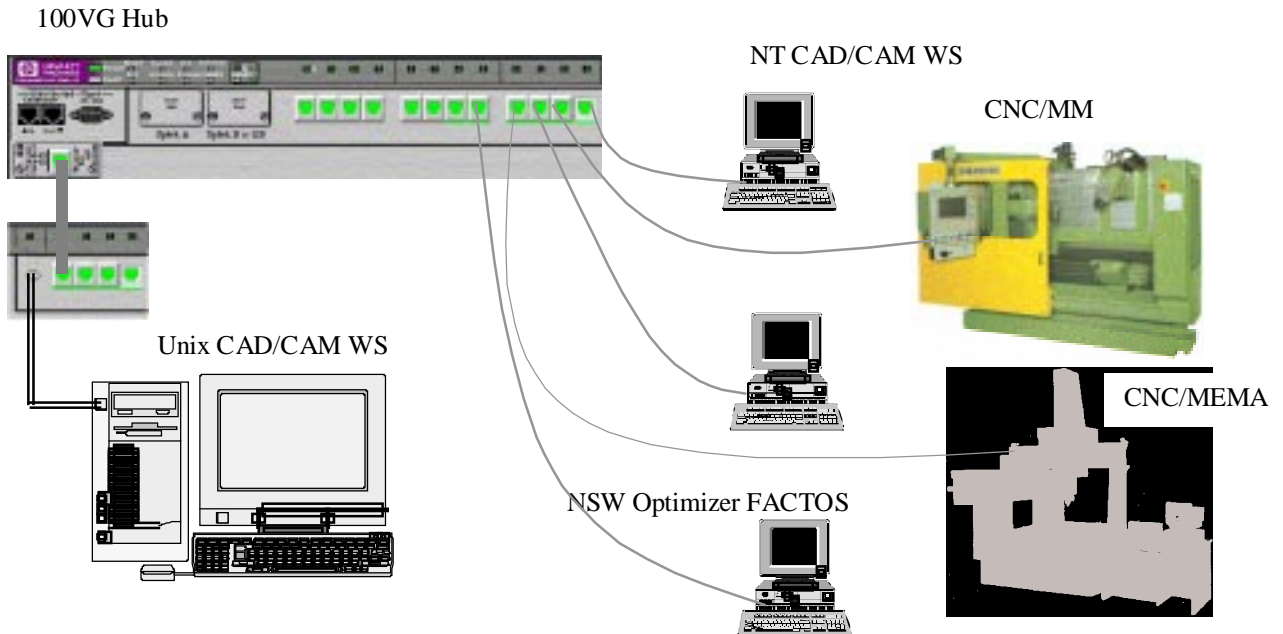

The hardware components used for the 100VG network used are summarized in the following table.

Hub	HP J2415A – AdvanceStack 100VG Hub-14
Bridge	HP J2414B HP 100VG/ET SNMP/Bridge Module
Transceiver	HP J2608 ThinLan
Network Adapter	HP J2585B DeskDirect 10/100VG PCI LAN Adapter
Cables	UTP Cat. 5
Connectors	RJ-45

The other components are a classical 10Base-T HUB with both RJ-45 and BNC connectors connected to the Bridge Transceiver of the 100VG Hub, the internal network adapter of the Unix WS connected to the 10Base-T Hub with a Thin coaxial with the standard BNC connector.

4.3.2 The Mock-Up Prototype

A mock-up prototype (also called FACTO) to validate the assumption made was implemented. It consists in a distributed application designed and implemented by using object-oriented technology, in particular the object-oriented methodology for system development will be used. At level of Management, the methodology of DSI and ELEXA will be applied.

The main tasks the prototype accomplish are:

1. *Activation of the remote execution* of CAD/CAM/Adaptation workstations on CNC and MEMA machines.
2. *Activation of file transfer* from the machine containing the file(s) and that which has to used it.
3. *The possibility of Monitoring and Measuring* in real-time the activity of the factory and that of its components.
4. *The possibility of Planning and Re-Planning* in real-time of the activities of CAD, CAM, Adaptation workstations, CNC and MEMA machines.

The two last points are based on the assumption of building a FACTO Server to organize schedule and make the all services that are available on the network to the several Clients. For these reasons, FACTO can be considered a sort of mechanism for virtualizing the services that are available on the network. The FACTO Server could be located in a machine dedicated to its execution. The Clients are located on CAD/CAM/Adaptation Workstations, on CNC, and on MEMAs. The ICCOC prototype can be considered the early demonstrator of FACTO architecture comprised of a Server and a set of possible Clients.

FACTO provide an User Interface for:

- FTP sessions. It is the basic network operation in CNC environment. Prototype grants:
 - Commands simplification: Ftp transfer requires a rigid command succession that can be totally automated to allow working time saving.
 - Security: prototype, by automatic localization and transfer, grants a selective access to files and directories to assure safety of other CNC operations.

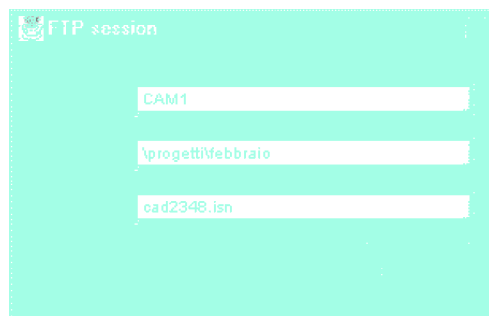

- Start CAD, CAM and measurement software remote operation: Prototype would open the remote session in the available network host by a simple button click.

- Java has several native classes for supporting distributed systems Remote Method Invocation (RMI) and interface Object Request Broker (ORB) for the accessing to Object Oriented Databases. These features have permitted to create on the server object which methods are executed directly by the clients.
- Java can execute code in native language (like C++) thanks to JNI. In Windows NT JNI allows the interface between Java and C++ DLL that can run native 32 bit applications.

4.3.3 Results

The prototype has been tested in real conditions at TECMA together with the test of network and of several other details about the integration.

Tests about Remote Execution

Remote execution is one of the principal applications that will be executed on the network. The remoting is obtained by the use of a specific terminal programs (e.g. X-WIN Pro of LabTam Corp.) that allows the visualization of a UNIX X Terminal on a CNC, Windows NT based station.

It is very important to measure both bandwidth used on the 100VG HUB and CPU Utilization for CNC Workstations during the execution of the various tests in order to verify the feasibility of operations.

Remote execution of the UNIX CAD and visualizing its GUI on ELEXA-CNC

In this test, under different three base workload conditions (0, 40 Mbps and 68.4 Mbps), the Unix CAD has been remoted on a CNC station, while another CNC station measures the load on the 100VG network. During the remoting of the application the increase in CPU Utilization for CNC has been monitored in order to verify the load on the station during the normal future operation. During this test the NC program is not running on CNC machine.

When Numeric Control (NC) Program is not running:

HUB Base Workload	0 Mbps	40 Mbps	68.4 Mbps
Load on The HUB	0.6 Mbps	40.6 Mbps	69 Mbps
Max Cpu Utilization	20%	20%	20%

When NC is running:

HUB Base Workload	0 Mbps	40 Mbps	68.4 Mbps
Load on The HUB	0.6 Mbps	40.6 Mbps	69 Mbps
Max Cpu Utilization	40%	40%	40%

Remote execution of the UNIX CAM with rendering and visualizing its GUI on ELEXA-CNC

During this test, under the previously cited different base workload conditions, the Unix CAM has been remoted on a CNC station, while another CNC station measures the load on the 100VG network. During the remoting of the application the increment in CPU Utilization for the CNC has been monitored in order to verify the load on the station during the normal future operations. During this test the NC program is not running on CNC machine.

When Numeric Control (NC) Program is not running:

HUB Base Workload	0 Mbps	40 Mbps	68.4 Mbps
Load on The HUB	0.6 Mbps	40.6 Mbps	69 Mbps
Max Cpu Utilization	20%	20%	20%

When NC is running:

HUB Base Workload	0 Mbps	40 Mbps	68.4 Mbps
Load on The HUB	0.6 Mbps	40.6 Mbps	69 Mbps
Max Cpu Utilization	40%	40%	40%

Tests about the Possibility of Remotely Control CNC from another CNC

Sometimes it's necessary that a single operator controls more than one CNC. In order to allow this mechanism it's necessary to remote the console of a CNC on other CNC.

This test allows measuring of the bandwidth necessary to perform such an operation, and the cost, in term of CPU utilization both for client and server CNC.

When NC is not running:

HUB Base Workload	0 Mbps	40 Mbps	68.4 Mbps
Load on The HUB	0.1 Mbps	40.1 Mbps	68.5 Mbps
Max Cpu Client Utilization	15%	15%	15%
Max Cpu Server Utilization	5%	5%	5%

When NC is running on client:

HUB Base Workload	0 Mbps	40 Mbps	68.4 Mbps
Load on The HUB	0.1 Mbps	40.1 Mbps	68.5 Mbps
Max Cpu Client Utilization	35%	35%	35%
Max Cpu Server Utilization	5%	5%	5%

When NC is running both on client and server:

HUB Base Workload	0 Mbps	40 Mbps	68.4 Mbps
Load on The HUB	0.1 Mbps	40.1 Mbps	68.5 Mbps
Max Cpu Client Utilization	35%	35%	35%
Max Cpu Server Utilization	25%	25%	25%

Tests about the Transferring Files

The first test performed consists in transferring files between two NT workstations and in particular from CNC/MM to CNC/MEMA station. In the second test the files have been transferred between a couple of stations M1, M2. At the same time M1 requests files from M2 and M2 requests file from M1.

Unidirectional FTP: in this test several files have been transferred. This test measures performance of file transfer between two 100VG Windows NT based workstations. Several files have been transferred and the mean Transfer Rate and the load on the network, under two different base workload conditions, have been measured.

Base Workload	28.8 Mbps	61 Mbps
Transfer Rate	7.4 Mbps	7,8 Mbps
HUB Load	36.8 Mbps	68.85 Mbps
Overhead on the HUB for each FTP session activated	< 2%	< 1 %

Bidirectional FTP: in this test several files have been transferred, but both the stations have been involved in FTP:

Base Workload	28.8 Mbps
Transfer Rate CNC1	7.5 Mbps
Transfer Rate CNC2	7.4 Mbps
Mean Transfer Rate	7,46 Mbps
HUB Load	46 Mbps
Overhead on the HUB for each FTP session activated	< 2.5 %

Tests about the Possibility of Measuring, Planning and Re-Planning

The optimization program FACTO (client program) did not generate a measurable load, because the throughput on the network was less than 0.1 Mbps. This client program did not provide a Cpu load greater than 2% on the less performing machine used in the network. The load on the network and the Cpu usage have been due to the remoting of CAD, CAM or FTP.

The mean measured response time of the client, when some client concurrently send query to the server, is about inversely proportional to the number of clients issuing queries.

Comments about Remote Execution Tests

Examining the results of all the previously presented tests and considering that the Execution of Windows NT provoke a maximum load of 2% on the Cpu, it is evident that a single CNC machine is able to perform all the operations tested at the same time. The percentage of Cpu that it is necessary to run CNC program is 20%, to remote a CAD is 20% (for CAM is 30%) and to remotely control another CNC station is 15%. When all the operations (NT+CAM+CNC Client+CNC Server) are performed at the same time, the total load on the Cpu is (2% + 20% + 30% + 15%) less than 70% and, therefore all the Cpu resources are not used. The load on the network is very low because each station that performs all the previously cited operation, generate a load less than 1 Mbps.

Comments about FTP sessions

This test demonstrates that about 6 bi-directional FTP session can be activated at the same time without collapsing the network.

The project has been completed and the work performed has demonstrated the faithfulness and the strong interest of such a product. This opinion is shared by TECMA and from other contacted end-users.

The solutions adopted in the mock-up prototype, implemented for the ICCOC project, can be profitably adopted as tested on the field. We found that:

- Remoting is feasible and cheap
- Remoting is well-considered by End-Users
- Network support chosen is adequate

- Real economical benefits have been detected by end-users

The benefits evaluated are:

- Reduction of costs for Re-CAD and Re-CAM: 60%
- Reduction of time for Re-CAD and Re-CAM: 20%
- Optimization of production process: saving 20%
- Re-qualification of "CNCer"

Thus a New Product and a New Market will be set.

The above opinions are shared by TECMA and from other contacted end-users.

4.4 Dissemination

4.4.1 Demonstrations

Some demonstrations have been given at TECMA; several other demonstrations are planned in order to verify if the requirements collected by visiting the end-users have been correctly interpreted.

An open-house will be organized as soon the suitable machines will be available in Florence, probably in October.

4.4.2 Dissemination Material

- Early version of WWW pages at <http://www.pdc.kth.se/pdcttn/machinery/> and <http://www.pdc.kth.se/pdcttn/machinery/factory.html>. Please see also the local page located in <http://aguirre.dsi.unifi.it/~hpcn/wwwiccoc/wwwpag.html>
- 70 Commercial Slides

4.4.3 Publications

- An article at the CSMR'98, IEEE, EUROMICRO,
- An article on Meccanica di Qualita' e Macchine, DeQualitate Magazine 1998 (1)

4.4.4 Contacts With End-Users

OMCS,	B-Ticino,	BVA,
Cevolín,	CB-Ferrari	CALP,
SL,	IMES	MPT,
Lucchese Stampi	Zago,	SMP

On The Basis of the Early Prototype some Concrete Agreements for implementing ISLANDs including ICCOC capabilities:

FABOHA (Germany)	ELSATECH (Italy)	ZAGO (Italy)
------------------	------------------	--------------

4.5 Conclusions

The key elements for building new products and for going towards an actual integration of the factory are:

- Remote execution of CAD, CAM, ADP, on CNC/MM and CNC/MEMA
- Monitoring the activity of the factory
- Planning and re-planning the activity in order to optimize the process of production.

So the aspect of Islands integration (MTs/MEMAs/Robots) and CAD/CAM/CNC integration must be integrated.

The ICCOC project has been focussed on CAD/CAM/CNC Integration.

The whole view is going to be obtained by merging the results of ICCOC with those obtained by ELEXA on Islands.

The solutions adopted in the mock-up prototype, implemented for the ICCOC project, can be profitable adopted as tested on the field. We found that:

- Remoting is feasible and cheap
- Is well-considered by End-Users
- Network support chosen is adequate
- Real economical benefits have been detected by end-users

The Costs for the real implementation of the mock-up prototype have been estimated about 900 d/m (concretely predicted on the basis of ICCOC feasibility study 15 classes x 3 x 20 days)

The benefits estimated are:

- Reduction of costs for Re-CAD and Re-CAM: 60%
- Reduction of time for Re-CAD and Re-CAM: 20%
- Optimization of production process: saving 20%
- Re-qualification of "CNCers"

Thus a New Product and a New Market will be set.

The above opinions are shared by TECMA and from other contacted end-users:

OMCS,	B-Ticino,	BVA,
Cevolín,	CB-Ferrari	CALP,
SL,	IMES	MPT,
Lucchese Stampi	Zago,	SMP

Several other demonstrations are planned in order to verify if the requirements collected by visiting the end-users have been correctly interpreted

On The Basis of the Early Prototype some Concrete Agreements for implementing ISLANDs including ICCOC capabilities:

FABOHA (Germany)	ELSATECH (Italy)	ZAGO (Italy)
------------------	------------------	--------------

This work will place also the basis for studying suitable policies for optimizing the exploitation of resources of the factory (CAD, CAM, CNCs, etc: a distributed application for optimizing the

exploitation of the resources in the factory: Measuring, Planning and Re-Planning in real-time of the activities of CAD, CAM, Adaptation workstations, CNC and MEMA machines..). The implementation of the algorithms of resources optimization and managing could be the subject of a bigger proposal and project in the same applicative domain.

Distributed application for optimizing the exploitation of the resources in the factory: Measuring, Planning and Re-Planning in real-time of the activities of CAD, CAM, Adaptation workstations, CNC and MEMA machines.

4.6 Contact Details

Contact Person: Marco Perfetti

ELEXA S.r.l.

(Project Coordinator, HPCN technology consumer: CNC builder)

Via delle Panche, 38 A, I 50141, Firenze, Italy

Phone: +39-55-43.51.19

Fax: +39-55-43.76.334

E-mail: elexa@tin.it

Contact person: Paolo Nesi

DSI (Department of System and Informatics)

(HPCN Technology provider)

University of Florence,

Via S.Marta, 3 A

I-50139 Firenze - ITALY

tel. +39 55 47.96.523

fax: +39 55 47.96.730

e-mail: nesi@dsi.unifi.it

WWW: <http://www.dsi.unifi.it/~nesi>

Contact person: Massimo Giorgetti

TECMA S.r.l. (End user: factory for producing templates)

Viale XX Settembre, 78

I-50019 Sesto Fiorentino, Firenze, ITALY

Phone: +39-55-44.42.41

Fax: +39-55-44.42.41

Some data about the project

Start: 15 July 1997 --- End: 15 Feb. 1998

Duration: 6 months

Total Costs: 58310 ECUs

Total Funding: 29155 ECUs (50%)

Man/year: 0.631

ELEXA Point of View

ELEXA builds Computerized Numerical Controls for Milling Machines, MMs, for making templates in unique pieces with very high precision of finishing on the machine. Templates are typically defined on CAD/CAM stations but their design must be frequently customized changing shape, and CAM parameters. This need leads to a heavy exploitation of CAD/CAM stations for considering issues strictly related to MMs, these are in turn very far from the CAD/CAM user mind-set. MMs for templates have to change, as fast as possible, their working program for each piece. Moreover, the description of these templates in terms of working program is very heavy since they must be produced with a high precision and this lead to have very large working programs -- e.g., several tenths of megabytes. Precision, also means to have very specialized and costly MMs. The pieces are defined on CAD/CAM stations but their design must be frequently customized changing shape, and CAM parameters. This need leads to a heavy exploitation of CAD/CAM stations for small and MMs-related issues that are in many cases very far from the CAD/CAM user mind-set. For these reasons, some builders have decided to integrate on CNCs for MMs also operations partially performed on CAD/CAM stations. For example, the visualization of working program (both in graphics and statements forms) for obtaining a specific mechanical piece, the implementation of coarse working programs on the basis of simple graphic editors. In the enterprises, which base their economy on producing templates, it is necessary to reduce as much as possible the time during which the machine does not work -- i.e., from the working of a template to the next one -- the so called dead time of MM.

ICCOC URL: <http://aguirre.dsi.unifi.it/~hpcn/wwwiccoc/wwwpag.html>

100VG Hub

NT CAD/CAM WS

CNC/MM

Unix CAD/CAM WS

CNC/MEMA

NSW Optimizer FACTOS

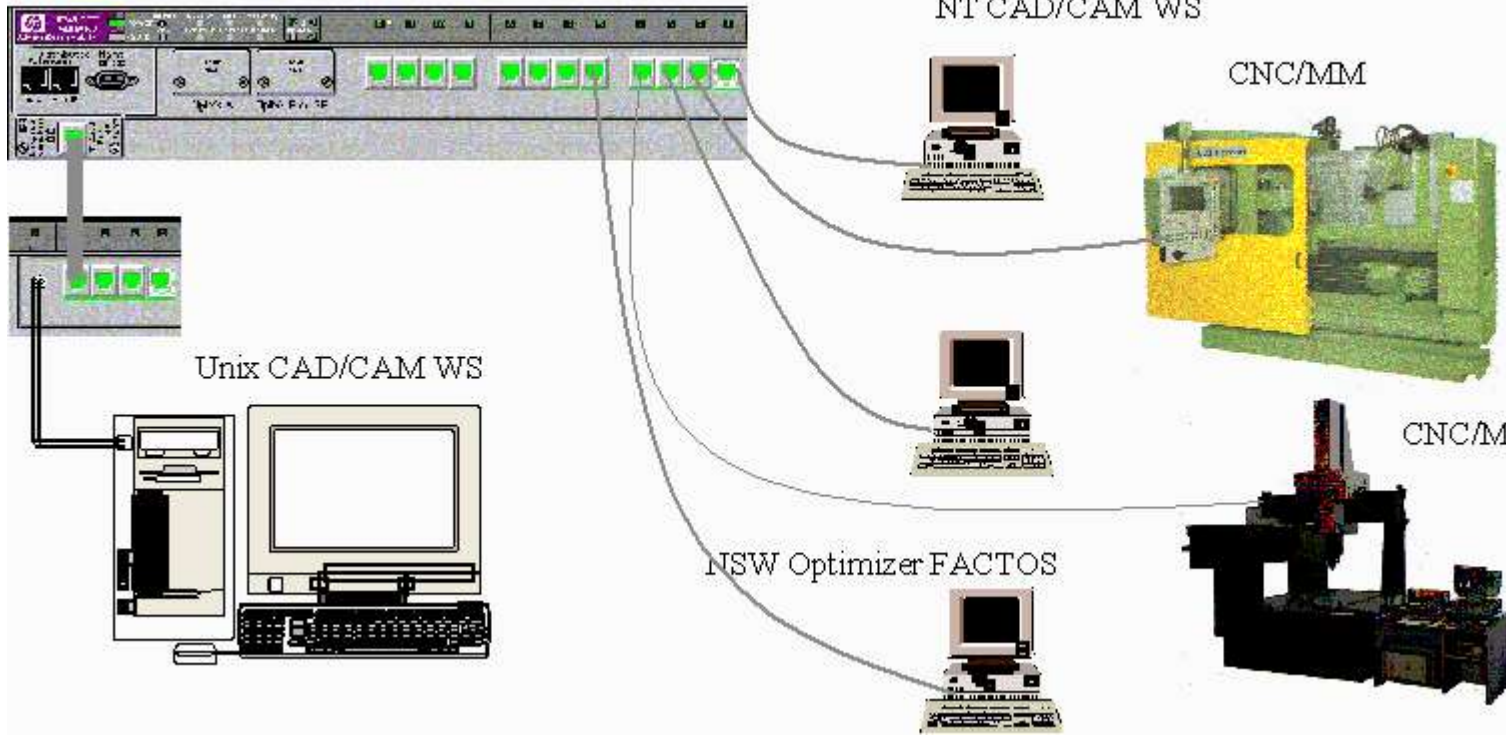

Test about Remote Execution

Remote execution is one of the principal applications that will be executed on the network. The remoting is obtained by the use of a specific terminal programs (e.g. X-WIN Pro of LabTam Corp.) that allows the visualization of a UNIX X Terminal on a CNC, Windows NT based station.

It is very important to measure both bandwidth used on the 100VG HUB and CPU Utilization for CNC Workstations during the execution of the various tests in order to verify the feasibility of operations.

Remote execution of the UNIX CAD and visualizing its GUI on ELEXA CNC

In this test, under different three base workload conditions (0, 40 Mbps and 68.4 Mbps), the Unix CAD has been remoted on a CNC station, while another CNC station measures the load on the 100VG network. During the remoting of the application the increase in CPU Utilization for CNC has been monitored in order to verify the load on the station during the normal future operation. During this test the NC program is not running on CNC machine.

When Numeric Control (NC) Program is not running:

HUB Base Workload	0 Mbps	40 Mbps	68.4 Mbps
Load on The HUB	0.6 Mbps	40.6 Mbps	69 Mbps
Max. Cpu Utilization	20%	20%	20%

When NC is running:

HUB Base Workload	0 Mbps	40 Mbps	68.4 Mbps
Load on The HUB	0.6 Mbps	40.6 Mbps	69 Mbps
Max. Cpu Utilization	40%	40%	40%

Remote execution of the UNIX CAM with rendering and visualizing its GUI on ELEXA-CNC

During this test, under the previously cited different base workload conditions, the Unix CAM has been remoted on a CNC station, while another CNC station measures the load on the 100VG network. During the remoting of the application the increment in CPU



Utilization for the CNC has been monitored in order to verify the load on the station during the normal future operations. During this test the NC program is not running on CNC machine.

When Numeric Control (NC) Program is not running:

HUB Base Workload	0 Mbps	40 Mbps	68.4 Mbps
Load on The HUB	0.6 Mbps	40.6 Mbps	69 Mbps
Max. Cpu Utilization	20%	20%	20%

When NC is running:

HUB Base Workload	0 Mbps	40 Mbps	68.4 Mbps
Load on The HUB	0.6 Mbps	40.6 Mbps	69 Mbps
Max. Cpu Utilization	40%	40%	40%

ICCOC URL: <http://aguirre.dsi.unifi.it/~hpcn/wwwiccoc/wwwpag.html>

Research Test Results

Test about the Possibility of Remotely Control CNC from another CNC

Sometimes it's necessary that a single operator controls more than one CNC. In order to allow this mechanism it's necessary to remote the console of a CNC on other CNC.

This test allows measuring of the bandwidth necessary to perform such an operation, and the cost, in term of CPU utilization both for client and server CNC.

When NC is not running:

HUB Base Workload	0 Mbps	40 Mbps	68.4 Mbps
Load on The HUB	0.1 Mbps	40.1 Mbps	68.5 Mbps
Max. Cpu Client Utilization	15%	15%	15%
Max. Cpu Server Utilization	5%	5%	5%

When NC is running on client:

HUB Base Workload	0 Mbps	40 Mbps	68.4 Mbps
Load on The HUB	0.1 Mbps	40.1 Mbps	68.5 Mbps
Max. Cpu Client Utilization	35%	35%	35%
Max. Cpu Server Utilization	5%	5%	5%

When NC is running both on client and server:

HUB Base Workload	0 Mbps	40 Mbps	68.4 Mbps
Load on The HUB	0.1 Mbps	40.1 Mbps	68.5 Mbps



Max. Cpu Client Utilization	35%	35%	35%
Max. Cpu Server Utilization	25%	25%	25%

ICCOC URL: <http://aguirre.dsi.unifi.it/~hpcn/wwwiccoc/wwwpag.html>

Test about the Transferring Files

The first test performed consists in transferring files between two NT workstations and in particular from CNC/MM to CNC/MEMA station. In the second test the files have been transferred between a couple of stations M1, M2. At the same time M1 requests files from M2 and M2 requests file from M1.

Unidirectional FTP: in this test several files have been transferred. This test measures performance of file transfer between two 100VG Windows NT based workstations. Several files have been transferred and the mean Transfer Rate and the load on the network, under two different base workload conditions, have been measured.

Base Workload	28.8 Mbps	61 Mbps
Transfer Rate	7.4 Mbps	7,8 Mbps
HUB Load	36.8 Mbps	68.85 Mbps
Overhead on the HUB for each FTP session activated	< 2%	< 1 %

Bi-directional FTP: in this test several files have been transferred, but both the stations have been involved in FTP:

Base Workload	28.8 Mbps
Transfer Rate CNC1	7.5 Mbps
Transfer Rate CNC2	7.4 Mbps
Mean Transfer Rate	7,46 Mbps
HUB Load	46 Mbps
Overhead on the HUB for each FTP session activated	< 2.5 %

Results

Tests about the Possibility of Measuring, Planning and Re-Planning

The optimization program FACTO (client program) did not generate a measurable load, because the throughput on the network was less than 0.1 Mbps. This client program did not provide a Cpu load greater than 2% on the less performing machine used in the network. The load on the network and the Cpu usage have been due to the remoting of CAD, CAM or FTP.

The mean measured response time of the client, when some client concurrently send query to the server, is about inversely proportional to the number of clients issuing queries.

ICCOC URL: <http://aguirre.dsi.unifi.it/~hpcn/wwwiccoc/wwwpag.html>